

# RT980

## SPECIFICATIONS



**GROVE MANUFACTURING COMPANY**

Division of Walter Kidde & Company, Inc.

**KIDDE**

SHADY GROVE, PA. 17256





## SUPERSTRUCTURE SPECIFICATIONS

**BOOM** — 36 ft. - 146 ft. (11.0m - 44.3m) total length; 4-section trapezoidal main boom consisting of base section and three full power sections to 114 ft. (34.6m) and a 32 ft. (9.8m) "swing-away" lattice boom extension to 146 ft. (44.3m). Power is supplied by three 6½ in. (165mm) diameter bore double-acting cylinders with integral holding valves. Boom telescope sections are supported on Nylatron wear pads. Side adjustable wear pads prevent metal-to-metal contact of inner boom sections and permit ease of boom side alignment.

**LATTICE BOOM EXTENSION** — Standard 32 ft. (9.8m) lattice "swingaway" boom extension stows alongside base boom section. Boom extension swings into position; attaches and is held to main boom nose with 4 corner pins. Single metallic 19½ in. (495mm) tread diameter sheave with removable, pin-type rope guard and rope dead-end.

**\*JIBS** — 28 ft. (8.5m) A-frame jib attaches to sheave shaft of the 32 ft. (9.8m) lattice "swingaway" boom extension. Jib stows beneath extension alongside base boom section, or can be detached from "swingaway" and held firmly in place on base section when extension is used independently. Jib can be offset at 5°, 15° and 30°. Includes jib backstops, single rope self-equalizing suspension and removable pin-type rope guard.

14 ft. (4.3m) lattice base section combines with the standard 32 ft. (9.7m) lattice "swingaway" boom extension to make basic 46 ft. (14.0m) jib. Additional 14 ft. (4.3m) pinned inserts available to make 60 ft. (18.3m), 74 ft. (22.6m) and 88 ft. (26.8m) jib lengths. Mast, pendant lines attaching hardware and backstops included in the makeup of all jib lengths. Jib sheave mounted on tapered roller bearings. The jib is cable suspended and can be offset at 5°, 17° and 30°.

**BOOM NOSE** — Reinforced hi-strength steel construction. Six metallic load bearing sheaves, 19½ in. (495mm) tread diameter, mounted on heavy duty tapered roller bearings. Two metallic floating idler sheaves 19½ in. (495mm) tread diameter mounted on bronze bushings. Removable pin-type rope guards for easy reeving. Rope dead ends on either side of the boom.

**\*AUXILIARY BOOM NOSE** — Removable single metallic sheave, 19½ in. (495mm) tread diameter, mounted to main boom nose for single part line work. Equipped with a removable pin-type rope guard.

**BOOM ELEVATION** — Dual 11 in. (279mm) diameter bore, double-acting hydraulic cylinders with integral holding valves. Elevation -4° to 80°, combination controls for hand or foot operation.

**SWING** — Grove planetary speed reducer powered by a hydraulic high torque, low RPM orbit motor providing smooth/precise 360° continuous rotation. Equipped with Grove "glide swing" with foot-activated multiple disc swing brake for precision stopping. Electric/hydraulic swing parking brake and hand-operated 360° positive swing lock controlled from operator's cab. Externally driven sealed gear bearing. Precision machined bearing mounting surface prevents distortion of swing circle hearing. Maximum speed 1.8 RPM.

**CAB** — Turntable-mounted. Fully enclosed, all steel with acoustical treatment. Full vision with tinted safety glass throughout, hinged skylight, sliding left side door and sliding right side window for ventilation. Dash-mounted control levers, combination hand and foot controls for boom elevation and engine throttle, outrigger sight leveling bubble, electronic boom angle indicator with high and low angle presets and A/V warning, electric windshield washer/wiper, steering wheel-mounted electric horn, door and window locks, domelight, dashlight, 2¼ lb. (1.3kg) dry-type fire extinguisher, cab mounted worklights, 20,000 BTU/Hr. diesel fuel heater, forced hot air defroster.

**CONTROLS** — Left of steering wheel are dash-mounted hand-operated control levers for swing, and boom-telescope; at right are control levers for rear steer, boom elevation, auxiliary hoist, main hoist and \*free-fall control. Foot-operated controls include dynamic swing brake, boom elevation, service brakes and engine throttle. Operator's right hand console includes transmission gear selection, high-low range selector, hand throttle, outrigger controls, sight leveling bubble, heater controls, console panel lights, engine start/stop. Additional dash-mounted controls include electric manual oscillation lockout override, worklights, master ignition and rear steer alignment indicator.

**CAB INSTRUMENTATION** — International gauges. Engine water temperature, fuel level, oil pressure, air pressure, tachometer, transmission and torque converter oil temperature and pressure, A/V warning for low air system pressure, and parking brake indicator.

**COUNTERWEIGHT** — Removable, bolted to turntable mast, stationary. Weight varies dependent on hoist configuration. (Refer to Axle Weight Distribution Chart).

**\*LOAD MOMENT & ANTI-TWO BLOCK SYSTEM (KRUEGER)** - Audio-visual warning in combination with Grove control lever lockout of: hoist-up, telescope out and boom down crane functions. Krueger LMI control console provides operator with selective display of boom length, radius and angle. \*A separate Grove anti-two block system can be obtained independent of the complete Krueger LMI, and is available with audio-visual warning only or audio-visual warning in combination with Grove control lever lockout of: hoist-up, telescope out and boom down crane functions.

\*Denotes optional equipment

† Patented Grove feature or patent pending



## HOIST SPECIFICATIONS

**DESCRIPTION:** Power up and down, equal speed, planetary reduction with integral automatic brake and electronic rotation indicators.

| HOIST DATA                                | MAIN HOIST<br>Grove Model HO30B-26  |   | AUXILIARY HOIST<br>Grove Model HO30B-16                                    |   | *AUXILIARY HOIST<br>Gearmatic Model 23<br>MGECR<br>(Controlled Free Fall)      |
|---|---|---|--|---|--|
| Drum Dimensions                           | 16 in. dia (406mm)<br>26 in. length (660mm)<br>24 in. flange dia. (610mm) |   | 16 in. dia. (406mm)<br>16 in. length (406mm)<br>24 in. flange dia. (610mm) |   | 14.5 in. dia. (368mm)<br>16 in. length (406mm)<br>22.3 in. flange dia. (568mm) |
| Performance:<br>Max. Single<br>Line Speed | Hi-Speed<br>Range<br>575 FPM<br>(175m/min)                                | Lo-Speed<br>Range<br>290 FPM<br>(88m/min) | Hi-Speed<br>Range<br>575 FPM<br>(175m/min)                                 | Lo-Speed<br>Range<br>290 FPM<br>(88m/min) | 422 FPM (129m/min)   |
| Max. Single<br>Line Pull                  | 8,400 lbs.<br>(3810kg)  | 16,800 lbs.<br>(7620kg)                   | 8,400 lbs.<br>(3810kg)   | 16,800 lbs.<br>(7620kg)                   | 11,700 lbs. (5307kg)   |
| Drum Rope<br>Storage Capacity             | **1,060 ft. of ¾ in. dia. rope<br>(323m of 19mm)                          |   | **650 ft. of ¾ in. dia. rope<br>(198m of 19mm)                             |   | **700 ft. of 5/8 in. dia. rope<br>(213m of 16mm)                               |
| Permissible Single<br>Line Rope Pull      | ¾ in. (19mm) 18x19 class -<br>14,605 lbs. (6625kg)                        |   | ¾ in. (19mm) 18x19 class -<br>14,605 lbs. (6625kg)                         |   | 5/8 in. (16mm) 18x19 class -<br>10,207 lbs. (4630kg)                           |

\*Denotes optional equipment. Auxiliary hoist control valve is standard equipment.

\*\*6th layer of rope not recommended for hoisting operation (7th layer for Gearmatic Model 23 Auxiliary Hoist).

## THREE MODES OF THE GROVE RT980 SWINGAWAY/JIB COMBINATION –

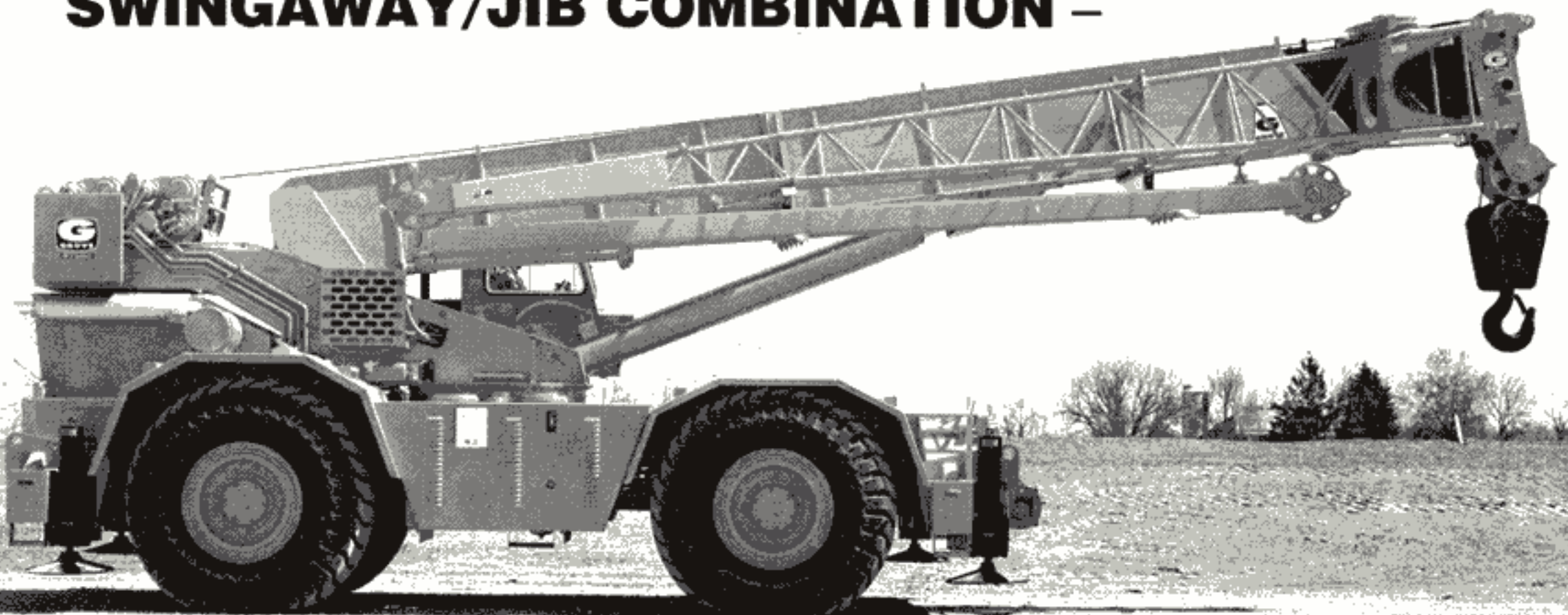

The 32 ft. Swingaway and optional 28 ft. A-frame jib can provide the RT980 with an additional 60 ft. of reach capability, conveniently stowed on the crane. The three different modes of this combination are:

1. Lifting from the main boom with the Swingaway extension and jib stowed alongside the base boom section.

2. Lifting from the main boom or Swingaway with the Swingaway erected and the jib stowed alongside the base boom section.

3. Lifting from the main boom, Swingaway, or jib with both Swingaway and jib erected.

# DIMENSIONS



TURNING RADIUS 23' (7010)  
TAIL SWING 14' 3" (4343)

NOTE: Figures in parentheses ( ) are metric equivalents expressed in millimeters.

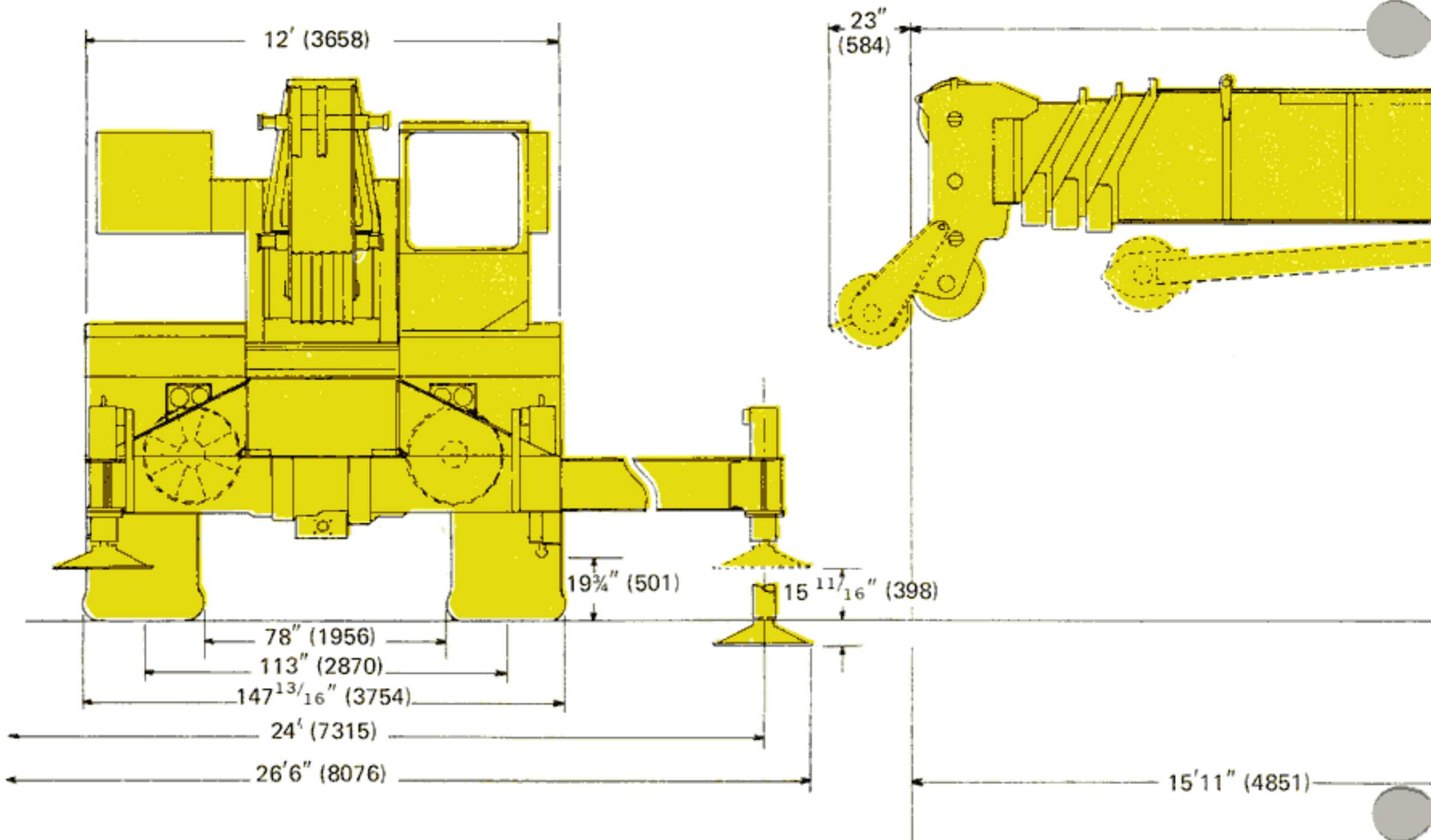

## SPEED AND GRADEABILITY

| Forward Drive | Transmission Range | Gear Shift | Maximum Speed |      | Gradeability @ Stall (%) | Tractive Effort at Stall |        |
|---------------|--------------------|------------|---------------|------|--------------------------|--------------------------|--------|
|               |                    |            | MPH           | KM/H |                          | LBS.                     | KG     |
| 4 Wheel Drive | Low                | 1st        | 1.4           | 2.3  | 81.9                     | 84,942                   | 38 530 |
| 4 Wheel Drive | Low                | 2nd        | 3.0           | 4.8  | 30.2                     | 40,139                   | 18 207 |
| 4 Wheel Drive | Low                | 3rd        | 7.6           | 12.2 | 9.4                      | 14,715                   | 6675   |
| 2 Wheel Drive | High               | 1st        | 4.0           | 6.4  | 20.9                     | 29,168                   | 13 231 |
| 2 Wheel Drive | High               | 2nd        | 8.0           | 12.9 | 8.6                      | 13,796                   | 6258   |
| 2 Wheel Drive | High               | 3rd        | 18.0          | 28.9 | 1.9                      | 5,058                    | 2294   |

**NOTE:** All performance data is based on standard machine and may vary plus or minus 10% due to variations in engine performance. Gradeability values above 45% are theoretical. Machines should be operated within the limits of engine crankcase design (30° - GM, 45° - Cat, 45° - Cummins).

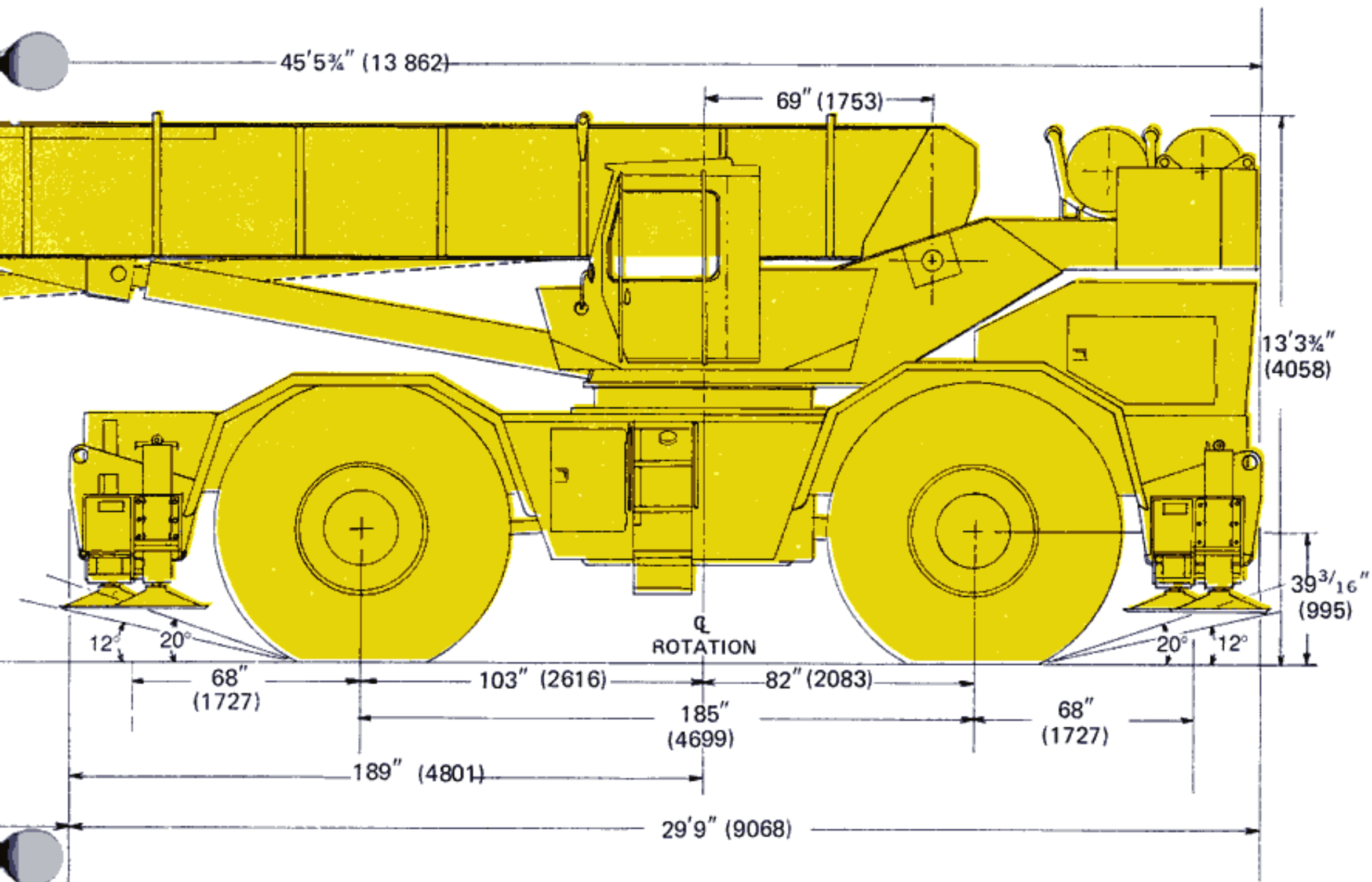





## CHASSIS SPECIFICATIONS

**MAIN FRAME** — All welded double parallel box beam construction with boxed cross-members to the rear of the frame and triple box construction to the front of the frame reinforced at critical points to resist torsional stresses and provide a strong, rigid lifting base. Precision machined bearing mounting surface prevents distortion of swing bearing. Front and rear combination lifting/towing and tie-down lugs are integral with main frame.

**OUTRIGGERS** — Front and rear hydraulic double-box integral with main frame; telescoping beams extend to 24 ft. (7.3m) center-to-center and retract to 12 ft. (3.7m) by 3 in. (76mm) bore double-acting cylinders. 23½ in. (597mm) stroke 7 in. (177mm) bore double-acting vertical jacks with integral check valves for quick leveling on uneven terrain. Vertical jacks equipped with removable, stowable, lightweight, high strength 30 in. (762mm) diameter steel floats. All outrigger controls located in operator's cab. Required sequence control arrangement eliminates unintentional outrigger actuation. In addition to the standard integral holding valve and for added security, the exclusive Grove \*spin-lock is offered which permits the outrigger vertical jack to be mechanically locked in any position throughout its stroke.

**TRANSMISSION & TORQUE CONVERTER** — Remote mounted full powershift transmission with six speeds forward and reverse with rear axle disconnect. Engine-mounted torque converter 2.16:1 stall ratio with PTO for hydraulic pumps.

**SPEEDS** — 6 forward and 6 reverse  
(3 speeds - High range — 2-wheel drive)  
(3 speeds - Low range — 4-wheel drive)

**AXLES** — Front: planetary drive/steer type mounted rigid to the frame. Total reduction ratio 32.07:1.

Rear: planetary drive/steer type mounted to allow 0 in. to 12 in. (305mm) oscillation for rough terrain negotiation. Total reduction ratio 32.07:1. Equipped with no-spin differential.

**HYDRAULIC OSCILLATION LOCKOUT** — Automatic, full hydraulic on rear axle. Permits rear axle oscillation only with boom over front. Rear axle lockout assures a rigid lifting platform when lifting on-rubber over-the-side. Manually-activated electric override control.

**STEERING** — Front — power assist hydraulic; controlled by steering wheel. Dual steering cylinders.

Rear — full hydraulic, tiller bar control. Dual steering cylinders. Independent front and rear steer control allows operator to choose mode of travel for optimum "on the move" maneuverability. Four modes available are: independent front wheel steer, independent rear wheel steer, 4-wheel coordinated steer and 4-wheel crab steer. \*Electric emergency power steering system provides power steering in the event of engine failure by means of a direct current motor powered by the crane's starter battery and energized when the power steering system pressure drops below a predetermined level. Warning light on dash indicates an energized emergency power steering system. Rear wheel steer alignment indicator provided.

**SERVICE BRAKES** — Full air on all four wheels. Size 28 in. x 8 in. (711mm x 203mm) with a total lining area of 896 sq. in. (5781cm<sup>2</sup>). Air dryer prevents moisture in the system for maximum braking efficiency. Equipped with a dual brake system for emergency backup air.

**PARKING BRAKES** — Spring-set emergency/parking brakes on all four wheels.

**TIRES** — 33.25 x 35 — 32 PR (E-3) Earthmover type, tubeless.

**\*TOW WINCH** — Braden PD15 cab-controlled, tow winch (less rope and hook), front mounted. Single line pull — 15,000 lbs. (6804kg); single line speed — 58.9FPM (17.9m/min.). Drum rope storage capacity of 340 ft. (103.6m) of ⅝ in. dia. (16mm) rope.

### HYDRAULIC SYSTEM:

**RESERVOIR:** 375 gallon (1419 liter) capacity, all-steel fabrication with internal baffles, clean-out access, exterior oil sight level gauge. Strap-mounted to frame to reduce high stress levels at corner welds. In-tank hydraulic oil temperature gauge.

**FILTER** — Tank mounted, return line replaceable cartridge with bypass protection and filter bypass indicator. 25 micron rating.

**PUMPS** — Two triple main gear pumps, (6 sections) 317 GPM (1120 LPM) combined capacity. Power steering pump 37 GPM (140 LPM) capacity. Pump disconnects for both main pumps are spring loaded to facilitate ease of engagement.

**CONTROL VALVES** — Precision four-way double-acting with integral load holding, main and circuit relief valves. Six individual valve banks permitting simultaneous independent control. Maximum operating pressure 2500 PSI (175.8kg/cm<sup>2</sup>).

**OIL COOLER** — Turntable-mounted, full flow, oil to air with thermally controlled hydraulic motor driven fan.

**POWER DISTRIBUTION** — Main hoist, auxiliary hoist boost — 51 GPM (193 LPM) @ 2500 psi (175.8kg/cm<sup>2</sup>); main hoist boost, auxiliary hoist, lift boost, inner mid telescope — 51 GPM (193 LPM) @ 2500 psi (175.8kg/cm<sup>2</sup>); lift — 51 GPM (193 LPM) @ 2500 psi (175.8kg/cm<sup>2</sup>); rear steer, outer mid telescope — 51 GPM (193 LPM) @ 2500 psi (175.8kg/cm<sup>2</sup>), fly telescope - 51 GPM (193 LPM) @ 2500 psi (175.8kg/cm<sup>2</sup>), swing, outriggers — 25 GPM (94.6 LPM) @ 2250 psi (158.1kg/cm<sup>2</sup>).

**MISCELLANEOUS STANDARD EQUIPMENT** — Complete light package, tool box and storage compartment, fenders, hook-block tie-down, combination lifting lugs, tow loops and tie-down attachments, front and rear pintle hook mounting brackets (less pintle hooks), ether injection cold start aid (less canister), engine air cleaner restriction indicator, audio-visual low boom angle swing alarm system, rear view mirrors, storage installation for removable windshield, hydraulic test panel, 3¾ lb. (1.7kg) dry type fire extinguisher, tire inflation kit.

**MISCELLANEOUS OPTIONAL EQUIPMENT** — Automatic, backup alarm, front and/or rear pintle hooks, hoist drum cable followers, pick and carry counterweight package.

*\*Denotes optional equipment*



## ENGINE SPECIFICATIONS

|                       | Detroit Diesel 6-71T               | *Cummins NT-855                     | *Caterpillar 3306TA                     |
|-----------------------|------------------------------------|-------------------------------------|---|
| MAKE & MODEL          | Detroit Diesel 6-71T               | *Cummins NT-855                     | *Caterpillar 3306TA                     |
| TYPE                  | 6 cylinder O.H.V.                  | 6 cylinder O.H.V.                   | 6 cylinder O.H.V.                       |
| BORE                  | 4.25 in. (108mm)                   | 5.5 in (140mm)                      | 4.75 in. (121mm)                        |
| STROKE                | 5 in. (127mm)                      | 6 in. (152mm)                       | 6 in. (152mm)                           |
| DISPLACEMENT          | 426 cu. in. (6982cm <sup>3</sup> ) | 855 cu. in. (14010cm <sup>3</sup> ) | 638 cu. in. (10 454cm <sup>3</sup> )    |
| HORSEPOWER (NET)      | 230                                | 219                                 | 230                                     |
| GOVERNED RPM          | 2100                               | 2100                                | 2100                                    |
| TORQUE (NET)          | 672 ft. lb. (92.9kg.m) @ 1600      | 696 ft. lb. (96.2kg.m) @ 1500       | 667 ft. lb. (92.2kg.m) @ 1450           |
| ELECTRICAL SYSTEM     | 12 volt, neg. grd.                 | 12 volt, neg. grd.                  | 12 volt, neg. grd.                      |
| STARTING SYSTEM       | 24 volt                            | 24 volt                             | 24 volt                                 |
| COMBUSTION SYSTEM     | 2 cycle w/blower and turbo-charger | 4 cycle w/turbo-charger             | 4 cycle w/turbo-charger and aftercooler |
| COOLING SYSTEM (CAP.) | Liquid – 14.5 gal. (54.9 liters)   | Liquid – 14 gal. (53 liters)        | Liquid – 14.25 gal. (53.9 liters)       |
| FUEL CAPACITY         | 100 gallons (379 liters)           | 100 gallons (379 liters)            | 100 gallons (379 liters)                |
| ALTERNATOR            | 90 AMP                             | 90 AMP                              | 90 AMP                                  |
| BATTERY               | •(4) 475 CCA @ 0°F                 | •(4) 475 CCA @ 0°F                  | •(4) 475 CCA @ 0°F                      |
| AIR CLEANER           | Dry type                           | Dry type                            | Dry type                                |
| AIR COMPRESSOR        | 12 CFM                             | 13.2 CFM                            | 12 CFM                                  |
| HOURMETER             | Standard                           | Standard                            | Standard                                |

•CCA = cold cranking amperage

\*Denotes optional equipment

## AXLE WEIGHT DISTRIBUTION CHART

| ITEM   | POUNDS  |         |         | KILOGRAMS |         |         |
|--|---------|---------|---------|-----------|---------|---------|
|  | GROSS   | FRONT   | REAR    | GROSS     | FRONT   | REAR    |
| Basic standard machine to include: 36 ft. - 114 ft. (11.0m - 34.6m) 4-section Trapezoidal main boom, 32 ft. (9.8m) Swingaway section, HO30B-26 main hoist with 750 ft. (228.6m) of 3/4 in. (19mm) dia. rope, HO30B-16 auxiliary hoist with *550 ft. (167.6m) of 3/4 in. (19mm) dia. rope, Detroit diesel 6-71T engine, •15,103 lbs. (6851kg) counterweight, 33.25x35-32 P.R. tires | 131,729 | 61,982  | 69,747  | 59,752    | 28,115  | 31,637  |
| <b>ADD:</b>  |         |         |         |           |         |         |
| Auxiliary boom nose  | +220    | +552    | -332    | +100      | +250    | -150    |
| 28 ft. (8.5m) A-frame jib (stowed)   | +1,582  | +1,739  | -157    | +718      | +789    | -71     |
| 80 ton (73mt) hook block   | +1,970  | +4,731  | -2,761  | +894      | +2146   | -1252   |
| Braden front mounted tow winch   | +936    | +1,390  | -454    | +425      | +631    | -206    |
| 20,000 lbs. (9,072kg) frame-mounted counterweight  | +20,000 | -10,810 | +30,810 | +9072     | -4903   | +13 975 |
| Brackets for frame-mounted counterweight   | +1,025  | -462    | +1,487  | +465      | -210    | +675    |
| Front carry deck   | +1,365  | +1,586  | -221    | +619      | +719    | -100    |
| <b>SUBSTITUTE:</b>   |         |         |         |           |         |         |
| ••• Gearmatic Model 23 MGEER auxiliary hoist with 550 ft. (167.6m) of 5/8 in. (16mm) dia. rope   | -686    | +254    | -940    | -311      | +115    | -426    |
| ••• 15,513 lbs. (7037kg) counterweight   | +410    | -151    | +561    | +186      | -68     | +254    |
| •• 16,863 lbs. (7649kg) counterweight  | +1,760  | -647    | +2,407  | +798      | -294    | +1092   |
| Cummins NT-855 engine  | +546    | -73     | +619    | +248      | -33     | +281    |
| Caterpillar 3306TA engine  | -       | -36     | +36     | -         | -16     | +16     |
| <b>REMOVE:</b>   |         |         |         |           |         |         |
| • HO30B-16 auxiliary hoist with 550 ft. (167.6m) of 3/4 in. (19mm) dia. rope   | -2,437  | +902    | -3,339  | -1105     | +410    | -1515   |
| 32 ft. (9.8m) Swingaway section  | -2,465  | -3,467  | +1,002  | -1118     | -1573   | +455    |
| 36 ft. - 114 ft. (11.0m - 34.6m) 4-section boom  | -24,510 | -28,965 | +4,455  | -11 118   | -13 139 | +2021   |
| 36 ft. - 114 ft. (11.0m - 34.6m) 4-section boom and lift cylinders   | -28,575 | -32,435 | +3,860  | -12 962   | -14 713 | +1751   |
| Tires and wheels   | -11,900 | -5,950  | -5,950  | -5398     | -2699   | -2699   |
| Outrigger beams and jacks (front)  | -4,360  | -5,963  | +1,603  | -1978     | -2705   | +727    |
| Outrigger beams and jacks (rear)   | -4,360  | +1,603  | -5,963  | -1978     | +727    | -2705   |
| • 15,103 lbs. (6851kg) counterweight   | -15,103 | +5,551  | -20,654 | -6851     | +2518   | -9369   |

**NOTE:** Appropriate counterweight substitutions must be made depending on main and auxiliary hoist configuration specified.

- 15,103 lbs. (6851kg) counterweight used with HO30B-26 main hoist and HO30B-16 auxiliary hoist.
- 16,863 lbs. (7649kg) counterweight used with HO30B-26 main hoist only.
- 15,513 lbs. (7037kg) counterweight used with HO30B-26 main hoist and model 23 MGEER auxiliary hoist.



## A RUGGED FRAME FOR A BIG LIFTER

The outstanding performance of the RT980 begins with the high-strength steel, double parallel box beam frame construction with boxed cross-members to the rear and triple box construction to the front. The entire frame is welded as a single unit, reinforced at critical points to resist torsional stresses and provide a strong, rigid lifting base. After assembly, the bearing mounting surface is precision machined to prevent distortion of the swing circle. Outrigger boxes are integral with the frame to provide additional strength and stability.

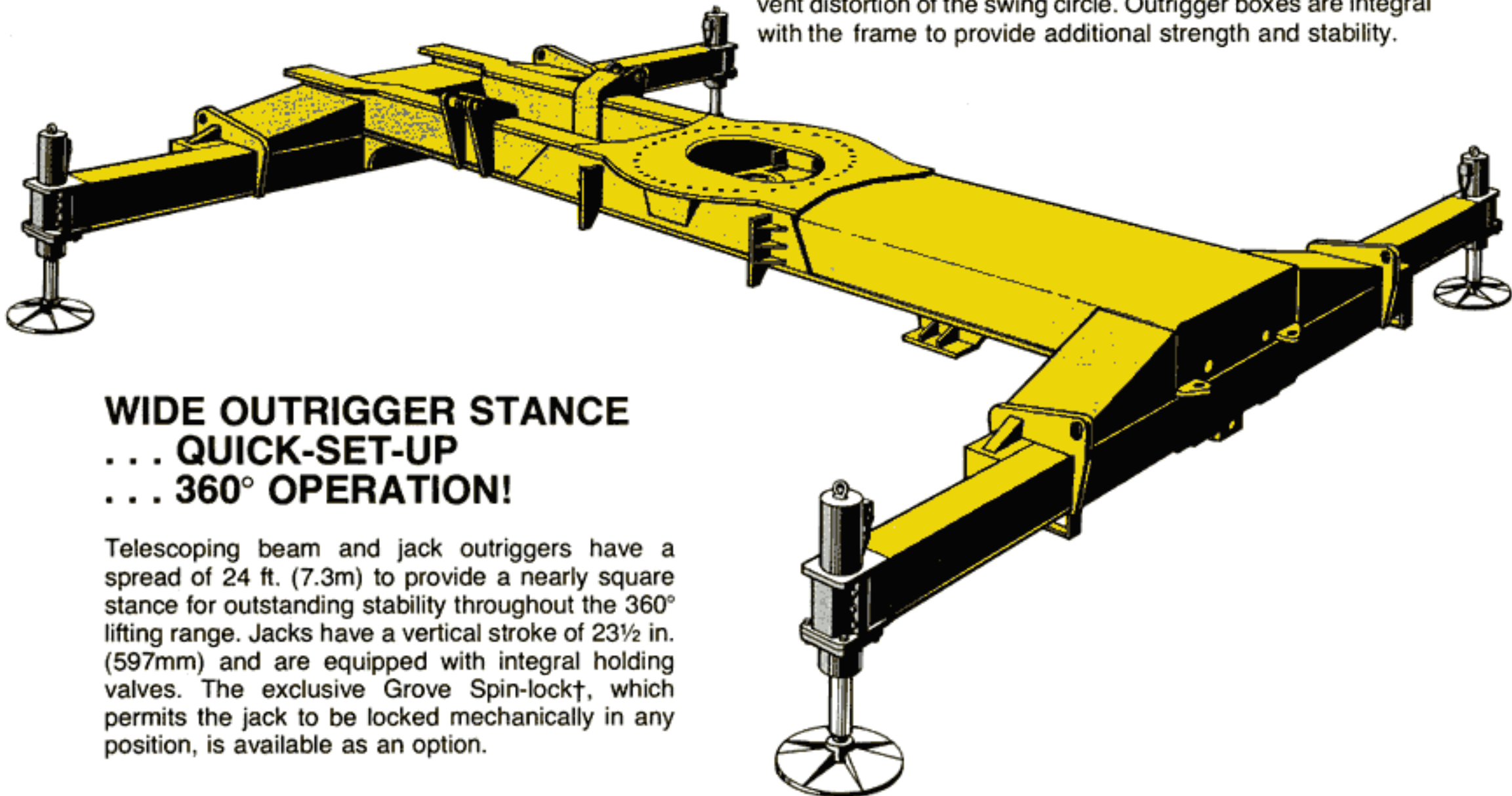

## WIDE OUTRIGGER STANCE ... QUICK-SET-UP ... 360° OPERATION!

Telescoping beam and jack outriggers have a spread of 24 ft. (7.3m) to provide a nearly square stance for outstanding stability throughout the 360° lifting range. Jacks have a vertical stroke of 23½ in. (597mm) and are equipped with integral holding valves. The exclusive Grove Spin-lock†, which permits the jack to be locked mechanically in any position, is available as an option.

## EASY MANEUVERABILITY

Full-power hydraulic steering with 4-steering modes permits 4-wheel coordinated, 4-wheel crabbing, 2-wheel (front or rear) steering for easier maneuvering in tight quarters. Grove's system of independent control for each axle permits a greater degree of maneuverability with greater ease for the operator.

