



PAT

**RATED CAPACITY LIMITER SYSTEM
DS 350**

TROUBLESHOOTING HANDBOOK

DS350/1225/1229 Console

Link-Belt

Construction Equipment

LATTICE BOOM CRANES



38 Years Specializing
in Crane Electronic Repair & Parts Sales
Call Us. We are glad to help

Bode Technical Services Inc
Email: contact-us@bodetechnical.com
Phone No.: +1.303.433.8878

NOTICE

The information in this document is subject to change without notice.

PAT makes no warranty of any kind with regard to this material, including, but not limited to the implied warranties of merchantability and fitness for a particular purpose.

PAT shall not be liable for errors contained herein or for incidental or consequential damages in connection with the furnishing, performance or use of this manual.

This document contains proprietary information which is protected by copyright. All rights are reserved. No part of this document may be photocopied, reproduced, or translated to another language without prior consent of PAT.





38 Years Specializing
in Crane Electronic Repair & Parts Sales
Call Us. We are glad to help

Bode Technical Services Inc
Email: contact-us@bodetechnical.com
Phone No.: +1.303.433.8878

TABLE OF CONTENTS

NOTICE

GENERAL INFORMATION..... 1

WARNINGS 1

1.0 ERROR CODE CHART 2

2.0 SYSTEM COMPONENT LAYOUT 6

3.0 ANGLE SENSOR ADJUSTMENT 7

 3.1 ANGLE CIRCUIT (WG203)..... 8

 3.2 ANGLE CIRCUIT (WG206)..... 9

4.0 LINERIDER SETTINGS AND ADJUSTMENTS..... 10

 4.0 General Information..... 10

 4.1 Linerider Zero Point Adjustment..... 11

 4.2 Linerider Output Adjustment..... 12

 4.3 Linerider Circuits 13

 4.4 Linerider Cannon Connection..... 14

5.0 DIGITAL INPUTS..... 15

6.0 ANTI-TWO BLOCK..... 16

7.0 BOOM BASE CABLE REEL DIAGRAM 16

8.0 MAIN BOOM / JIB JUNCTION BOX DIAGRAMS 17

9.0 LUFFING JIB JUNCTION BOX DIAGRAMS..... 18

10.0 SYSTEM (12 VOLT) WIRING DIAGRAM 19

 10.1 Vertical Console Diagram 20

11.0 SYSTEM (24 VOLT) DIAGRAM..... 21

 11.1 Horizontal Console Diagram 22

12.0 TERMINAL BOARD DESIGNATIONS 23

13.0 MAIN BOARD MEASURING POINTS 24





38 Years Specializing
in Crane Electronic Repair & Parts Sales
Call Us. We are glad to help

Bode Technical Services Inc
Email: contact-us@bodetechnical.com
Phone No.: +1.303.433.8878

GENERAL INFORMATION

This handbook defines the error codes, cause, and actions to troubleshoot the PAT DS 350 Rated Capacity Limiter (RCL) System for Link-Belt Lattice-Boom Cranes.

Refer to the operating handbook for operation and maintenance of the PAT DS 350 Rated Capacity Limiter (RCL).

This system assists the crane operator in promoting efficient operation by monitoring crane loads and by warning the operator of approaching overload conditions. Always refer to operational instructions and load charts provided by the crane manufacturer for specific crane operation and load limits.

WARNINGS

- The operator is always responsible for operating the crane within the manufacture's specified parameters.
- The PAT DS 350 Rated Capacity Limiter (RCL) is an operational aid which warns a crane operator of an approaching overload and over hoist condition which could cause damage to equipment, property, and/or injury to the operator or bystanders.
- This device is not, and shall not be a substitute for good judgment, experience, and the practice of accepted safe crane operation.
- The operator is solely responsible for the safe operation of the crane and must observe and obey all warnings and instructions supplied by PAT and the crane manufacturer.
- Prior to operating a crane, the operator must carefully and thoroughly read and understand the information in operator's handbook and the crane manufacturer's manual to ensure that the operator understands the function and limitations of the RCL system and the crane.
- Proper operation of the RCL System is dependent upon proper inspection, maintenance, and observance of the operating instructions.

1.0 ERROR CODE CHART

ERROR DISPLAY	ERROR	CAUSE	ACTION
E 01	Fallen below radius or angle range	Fallen below the minimum radius or angle given in the load chart due to rising the boom too far.	Put boom back to a radius or angle given in the load chart.
E 02	Radius or angle range exceeded.	The maximum radius or angle given in the load chart was exceed due to lowering the boom too far.	Raise boom back to a radius or angle given in the load chart.
E 03	Prohibited slewing range (no load area).	Slewing range prohibited with load.	Slew back into permissible range.
E 04	Operating mode not available.	Operating mode switch on the console set incorrectly.	Set operating mode switch correctly to the code assigned to the operating mode of the machine. (see Section 9 operator's handbook)
E 06	Angle luffing jib exceeded.	The minimum angle given in the corresponding load chart was exceeded due to lowering the luffing jib too much.	Raise luffing jib to an angle given in the load chart.
E 07	No acknowledge signal from overload relay.	Over load limit switch relay is stuck, defective, or not being selected.	Replace relay
E 08	No acknowledge signal from hoist limit switch relay	Hoist limit switch relay is stuck, defective, or not being selected.	Replace relay
E 09	No acknowledge signal from relay 2.	Relay 2 is stuck, defective, or not being selected.	Replace relay
E 13	Fallen below lower limiting value for the measuring channel "auxiliary force".	Cable from central unit to the force transducer defective or water in the plugs. Electronic component in the measuring channel defective.	Check cable and plugs; replace items as necessary. See Section 3, force transducer adjustments.
E 14	Fallen below lower limiting value for the measuring channel "force-main hoist".	Cable from central unit to the force transducer defective or water in the plugs. Electronic component in the measuring channel defective.	Check cable and plugs; replace items as necessary. See Section 3, force transducer adjustments.
E 15	Fallen below lower limiting value for the measuring channel "angle main boom".	Cable from central unit to the angle sensor defective or loose, or water in the plugs. Electronic component the measuring channel defective.	Check cable and plugs; replace items as necessary. See Section 2, angle sensor adjustments.



1.1 ERROR CODE CHART - continued

ERROR DISPLAY	ERROR	CAUSE	ACTION
E 16	Fallen below lower limiting value for the measuring channel "angle luffing jib".	Cable from central unit to the angle sensor defective or loose, or water in the plugs. Electronic component the measuring channel defective.	Check cable and plugs; replace items as necessary. See Section 2, angle sensor adjustments.
E 18	Error in the reference voltage.	Electronic component on main board defective.	Replace main board & reset force transducers as shown in Section 3.2.
E 19	Error in the reference voltage.	Electronic component on main board defective.	Replace main board & reset force transducers as shown in Section 3.2.
E 20	No analog voltage.	Crane voltage to low Short in supply voltage from crane to central unit. Voltage converter is defective on main board	Check crane voltage Check wiring Replace main board & reset force transducers as shown in Section 3.2.
E 23	Upper limiting value for the measuring channel "auxiliary-force" exceeded.	Cable from central unit to the force transducer defective or water in the plugs. Electronic component in the measuring channel defective.	Check cable and plugs; replace items as necessary. Replace main board & reset force transducers as shown in Section 3.2.
E 24	Upper limiting value for the measuring channel "force - main hoist" exceeded.	Cable from central unit to the force transducer defective or water in the plugs. Electronic component in the measuring channel defective.	Check cable and plugs; replace items as necessary. Replace main board & reset force transducers as shown in Section 3.2.
E 25	Upper limiting value for the measuring channel "angle main boom" exceeded.	Cable from central unit to the angle sensor defective or loose, or water in the plugs. Electronic component the measuring channel defective.	Check cable and plugs; replace items as necessary. See Section 2, angle sensor adjustments.
E 26	Upper limiting value for the measuring channel "angle luffing jib" exceeded.	Cable from central unit to the angle sensor defective or loose, or water in the plugs. Electronic component the measuring channel defective.	Check cable and plugs; replace items as necessary. See Section 2, angle sensor adjustments.



1.2 ERROR CODE CHART - continued

ERROR DISPLAY	ERROR	CAUSE	ACTION
E 28	Error in the reference voltage.	Electronic component on main board defective.	Replace main board & reset force transducers as shown in Section 3.2.
E 31-34	Error in system software.	Eprom's with system software defective.	Replace system Eprom Replace main board & reset force transducers as shown in Section 3.2.
E 37	Error in system software.	Eprom's with system software defective.	Replace system Eprom Replace main board & reset force transducers as shown in Section 3.2.
E 38	Wrong system or data Eprom.	Eprom's with system software does not correspond with data Eprom.	Replace system Eprom
E 41-42	Error on the ram.	Ram range on the main board defective.	Replace main board & reset force transducers as shown in Section 3.2.
E 45	Error in internal communications Error in read/write memory.	Electronic component on main board defective. Electronic component on main board defective	Replace main board & reset force transducers as shown in Section 3.2.
E 51-59	Error in data memory.	Data Eprom's defective Electronic component on main board defective.	Replace data Eprom Replace main board & reset force transducers as shown in Section 3.2.
E71	Incorrect acknowledgment of the 1. Relay on the terminal board a101.	Anti two-block relay is stuck or defective. Anti two-block relay is not being selected due to a break on the terminal board a101, main board or ribbon cables.	Replace 1. Relay. Check terminal board a101, main board and ribbon cables as well as replace defective part, if necessary.
E72 - 77	analogous to E71 for the relays 2...7.	Analogous to e71 for the relays 2...7.	Analogous to E71 for the relays 2..7.
E89	Change of the operating code during lifting a load.	The operating mode switch in the console was used during lifting a load.	Lower the load and set the operating mode switch correctly to the code assigned to the actual operating mode of the crane.



1.3 ERROR CODE CHART - continued

ERROR DISPLAY	ERROR	CAUSE	ACTION
E 91-92	No data transmission from console.	Plug on console loose; cable defective.	Check cable and plug; replace console, as necessary.
E 93-94	Error in the data transmission to the console.	Cable to the console not plugged in or interrupted. Eprom not installed or defective Defect in the central electronics (main board).	Check cable; attach plug properly. Replace Eproms Replace main board & reset force transducers as shown in Section 3.2.

E-19/20/29 Error in reference supply voltage. Identify supply voltage that is being shorted, (+/-5 or + -9) disconnect ribbon cable. If power supply returns then problem is external. Reconnect ribbon cables and disconnect all components individually to identify the location of the short.

2.0 SYSTEM COMPONENT LAYOUT

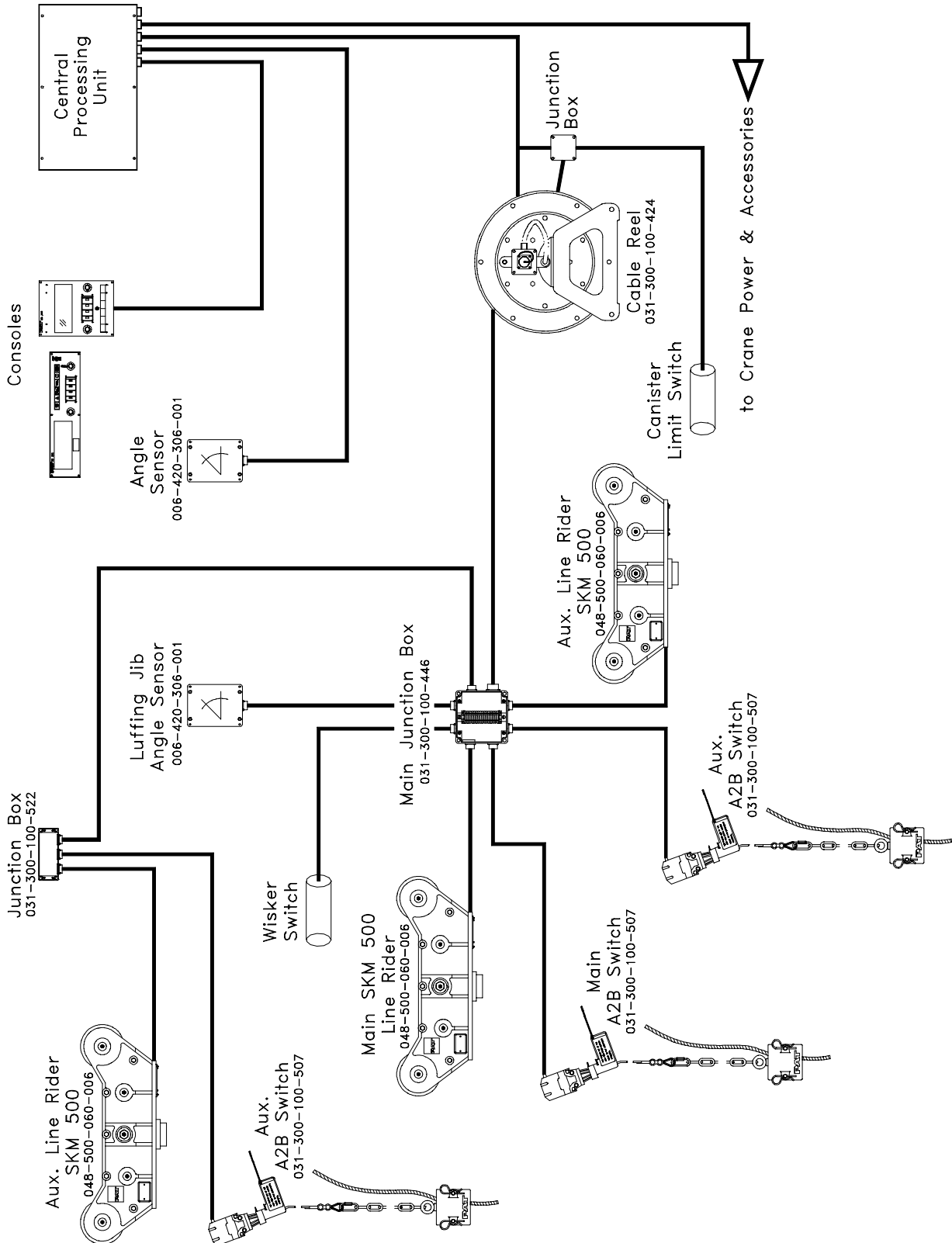

3.0 ANGLE SENSOR ADJUSTMENT

The angle ϕ shown in Figure 1 needs to be within +0, -0.4 of the actual angle of the boom. Check boom angle at base/heel Section only. After adjustment, compare the actual boom angle with the displayed angle at about 0°, 30° and 60°. To comply with the SAE J375 standards the displayed angle must be +0.0° to -2.0° of the actual angle.

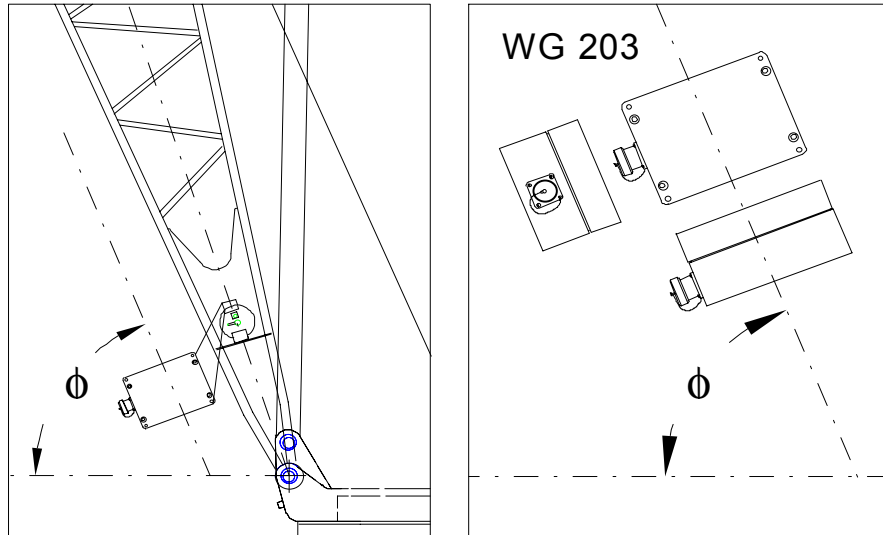
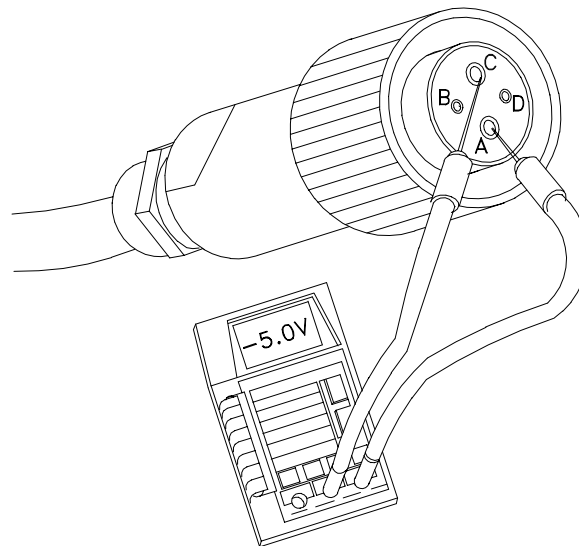

Figure 1. Angle Sensor Adjustment.

The supply voltage can be checked directly at the cannon connection. Using a digital volt meter measure between pins A and C, (A=GND, C= - 5V). If this voltage is not correct refer to the system wiring diagram and verify all cable connections. You may need to start at the main board and check the supply voltages at their proper measuring points.



The following 2 drawings show the theory of operation for the main and luffing angle signals.

3.1 ANGLE SENSOR CIRCUIT (WG203)

DRAWING # - LKB24-03

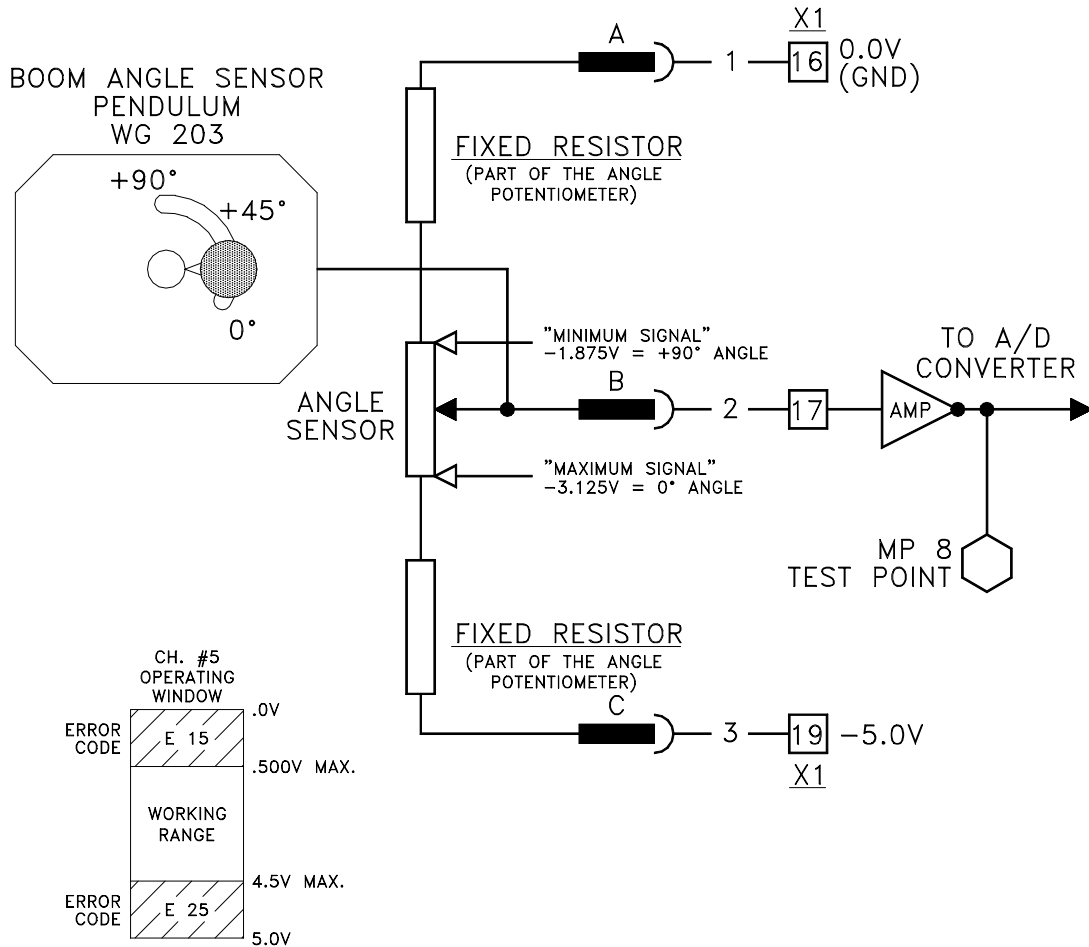

MP 8 VOLTAGES

- +90° ANGLE MIN. SIG. = +500mV (.500V)
- +45° ANGLE = +2.50V
- 0° ANGLE MAX. SIG. = +4.50V

NOTE: ALL VOLTAGES ARE MEASURED WITH REFERENCE TO GND (TERMINAL X1-16 OR MP15) ON MAIN BOARD

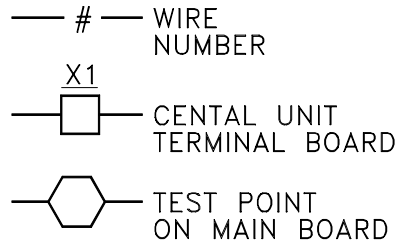

3.2 ANGLE SENSOR CIRCUIT (WG206)

DRAWING # - LKB24-04

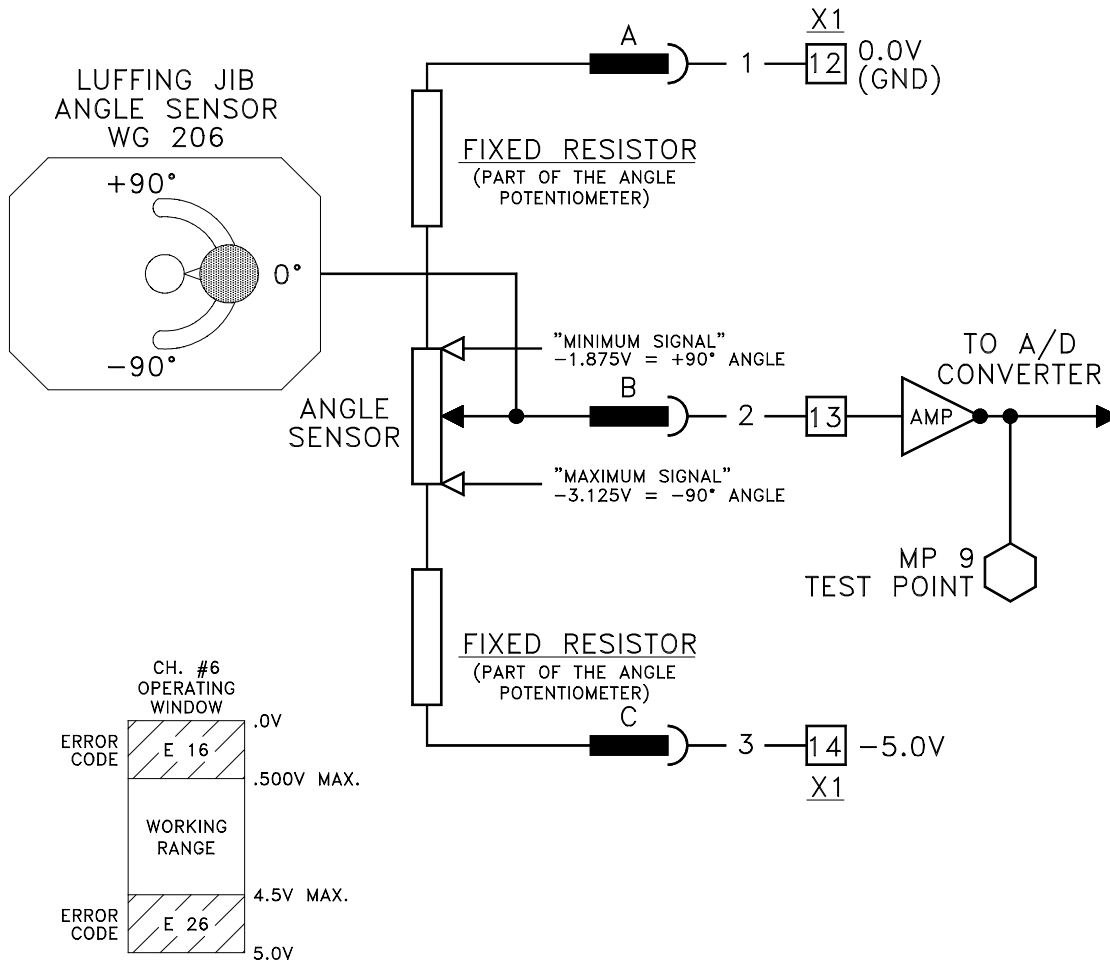

MP 8 VOLTAGES

+90° ANGLE MIN. SIG. = +500mV (.500V)
 0° ANGLE = +2.50V
 -90° ANGLE MAX. SIG. = +4.50V

NOTE: ALL VOLTAGES ARE MEASURED WITH
 REFERENCE TO GND (TERMINAL X1-12 OR MP15)
 ON MAIN BOARD

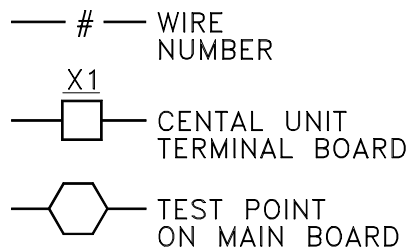

4.0 LINERIDER SETTINGS AND ADJUSTMENTS

4.1 GENERAL INFORMATION

Calibration of a linerider will require the hoist rope line pull information, which should be provided by the manufacturer. Use single part line when calibrating the linerider. Lineriders require specific wire rope size, see Table 2 to insure your rope size matches your linerider provided.

NOTE: A new wire rope is normally over sized, the amount oversize will depend on the diameter of the rope. With normal wear the inter core breaks down and diameter decreases, See your manufactures guide lines for wire rope replacement conditions.

Table 2. Lineriders should match the wire diameter of your hoist rope.

ITEM NUMBER	DESCRIPTION WITH WIRE ROPE SIZE	WIRE ROPE DIAMETER ADVISED RANGE
048-500-060-005	SENSOR, LINERIDER SKM500 7/8"	±3/64
048-500-060-006	SENSOR, LINERIDER SKM500 1"	±3/64
048-500-060-012	SENSOR, LINERIDER SKM500 1-1/8 2 TON KMD	±3/64
048-500-060-013	SENSOR, LINERIDER SKM500 1-1/4 2 TON KMD	±1/16

The linerider requires a load sheave adjustment to maximize the voltage output of the amplifier and minimize the line angle through the linerider. The linerider maximum output of 2.5 volts should be equal to the maximum hoist rope line pull. The load sheave may need to be adjusted by turning the eccentric wheel on the load sheave of the SKM500 linerider, see figure below.

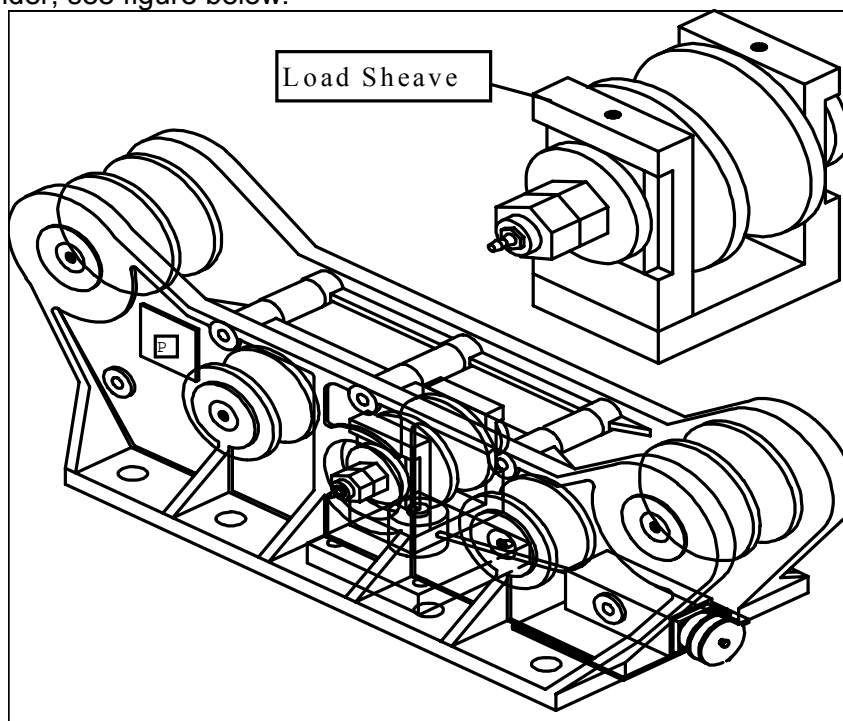

4.1 LINERIDER ZERO POINT ADJUSTMENT

NOTE: Complete the following processes before placing cable through the linerider.

ZERO POINT SETTINGS

- a.) Check that the differential output of the main and auxiliary linerider is within ± 25 millivolts at zero force:
 - Main Linerider: central unit terminal connection X1-#33 and X1-#34.
 - Auxiliary linerider: central unit terminal connection X1-#23 and X1-#24.
- b.) Adjust the linerider voltages on the main board, Refer to Figure 2 below.

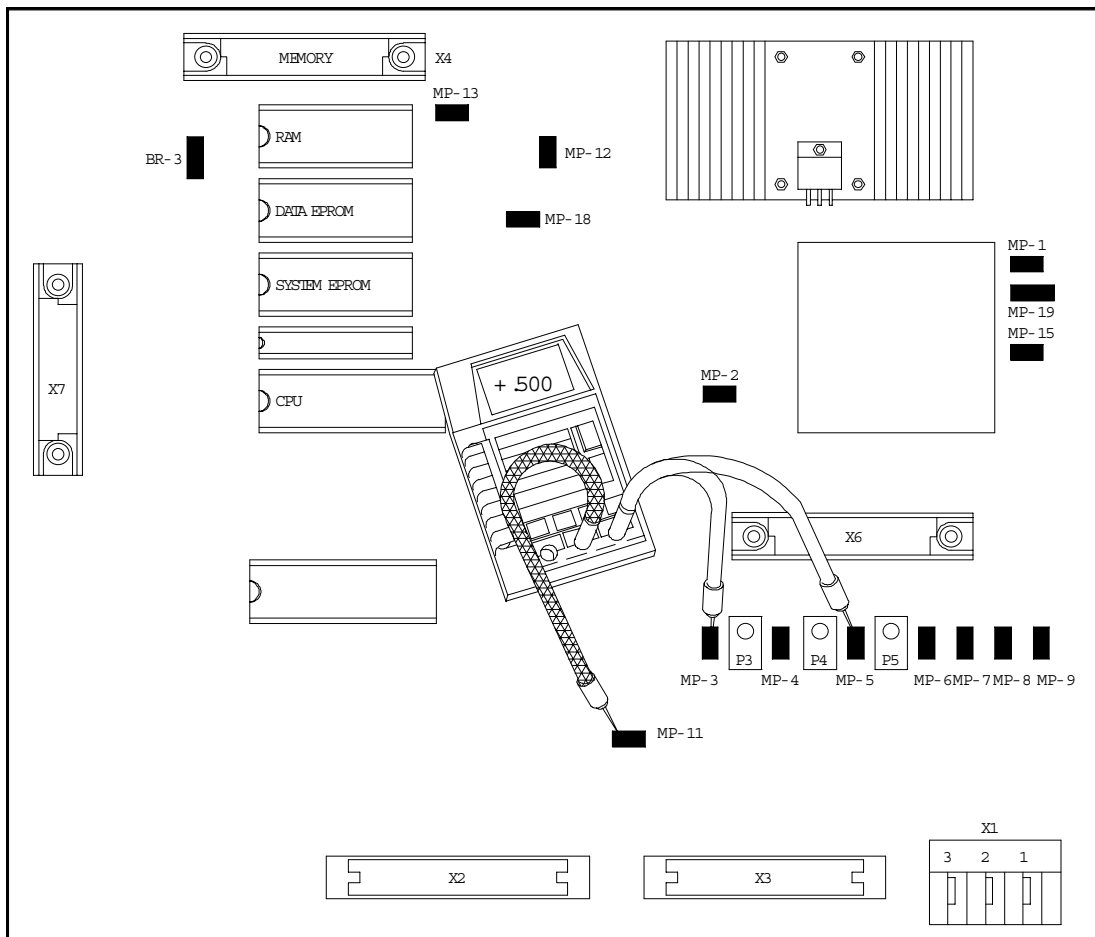

Figure 2. Main Board

- Adjust the main linerider zero point by placing your positive volt meter lead on MP 3 (measuring point 3) with your ground lead on MP 11. Turn the screw on potentiometer P3 so the volt meter reads a value of 0.500 volts.
- Adjust the auxiliary linerider by placing your positive volt meter lead on MP 5 with your ground lead on MP 11. Turn the screw on potentiometer P5 so the volt meter reads a value of 0.500 volts.
- After completing this adjustment run the hoist rope through the lineriders.

4.2 LINERIDER OUTPUT ADJUSTMENT

LINERIDER OUTPUT ADJUSTMENTS

- a) Calculate the output voltage required from the linerider using the known the total load and maximum line pull information. The tolerance for the output voltage "X" is +0.0, -0.2 volts.

NOTE: The total load includes the load, rigging, cables, and hook block. Test load should be 80% of maximum rated load for the cranes configuration or condition. To comply with the SAE J376 standards the test load must be to a known accuracy of $\pm 1\%$.

$$\frac{\text{TEST LOAD} \times 2.5}{\text{LINE PULL}} = \div \text{PARTS OF LINE} = X$$

$$\frac{23.600 \times 2.5}{29.500} = 2.0 \div 1 = 2.0$$

"X" is equal to the to optimum output voltage of the linerider. The output voltage required in this example is 1.8 to 2.0 volts.

WARNING: THE OPERATOR IS RESPONSIBLE FOR OPERATING THE CRANE WITHIN THE MANUFACTURE'S SPECIFIED PARAMETERS.

- b) Pick the test load used in the calculation for the output voltage with a single part of line.
- c) Take a voltage reading with a voltmeter and compare the reading with the calculated voltage and decide if a mechanical adjustment of the linerider is needed.
- Main Linerider: central unit terminal connection X1-#33 and X1-#34.
 - Auxiliary linerider: central unit terminal connection X1-#23 and X1-#24.
- d) If a mechanical adjustment is necessary follow steps below, if no mechanical adjustment is necessary proceed to next Section and begin calibration.
- Before and after you set the mechanical adjustment, scribe a line on the side of the eccentric wheel to show the amount of change.
 - Loosen the adjustment nut, see Figure 3. Note that there is a single lockout nut on one side and a double on the other. These both should be loosened to some degree. Adjustment from the double nut side seems to work the best after tightening the 2 nuts together.
 - Depending upon the output voltage you can look at the eccentric nut from the side of the linerider and determine the direction you should turn. Increasing the height of the load sheave will increase the output voltage.
 - Tighten all lock nuts insuring not to move the wheel.
- e) Return and repeat step 'c'.

4.3 LINERIDER CIRCUIT (MAIN LINERIDER)

DRAWING # - LKB24-01

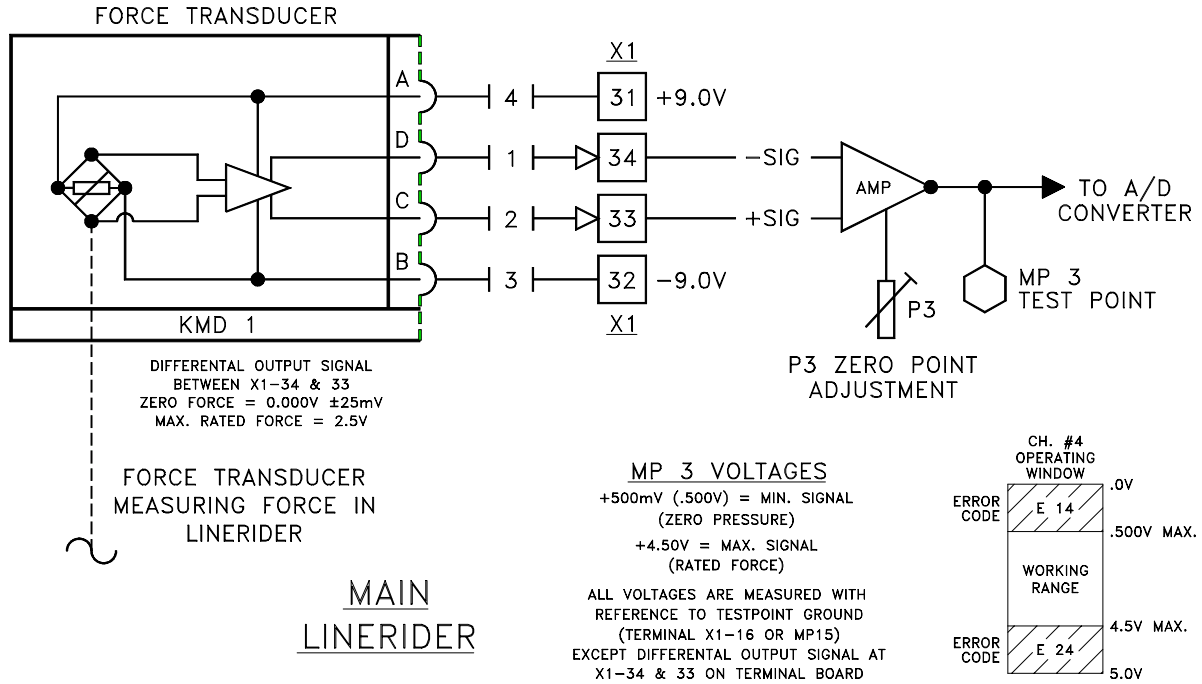

DRAWING # - LKB24-02

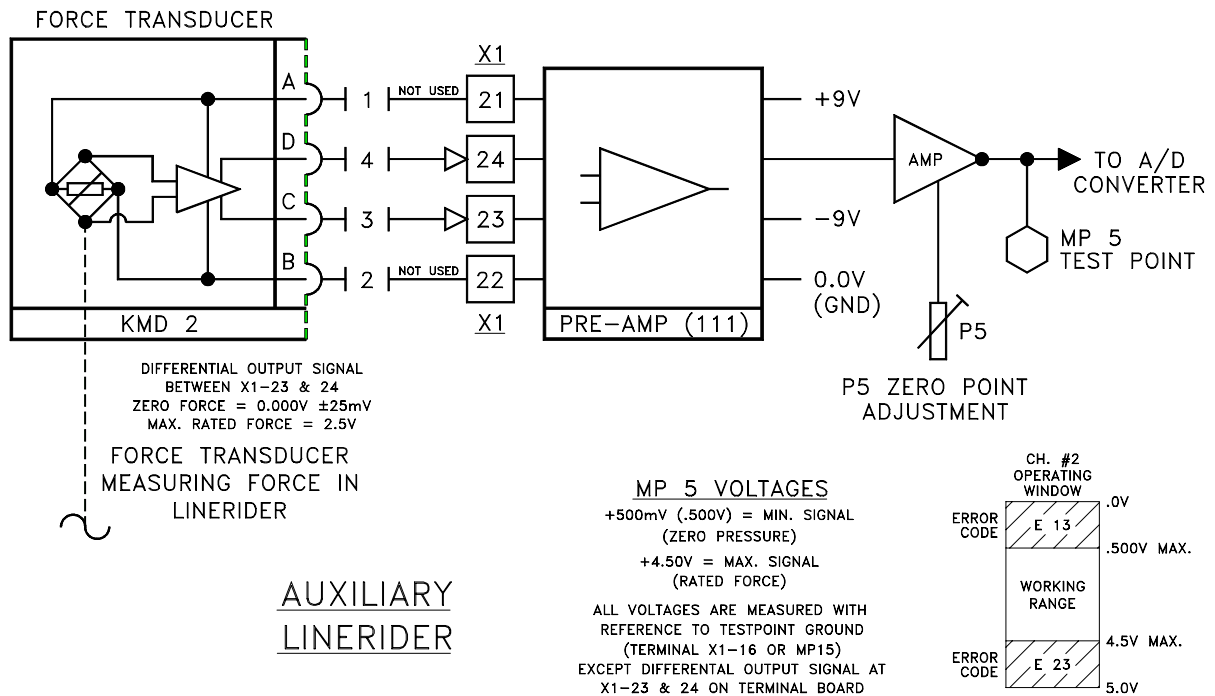

4.4 LINERIDER CANNON CONNECTION

LINERIDER CANNON CONNECTION

The supply voltage can be checked directly at the cannon connection. Using a digital volt meter measure between pins A and B, (A= + 9v) + (B= - 9v) = 18volts. If this voltage is not correct refer to the system wiring diagram and verify all cable connections. You may need to start at the main board and check the supply voltages at their proper measuring points.

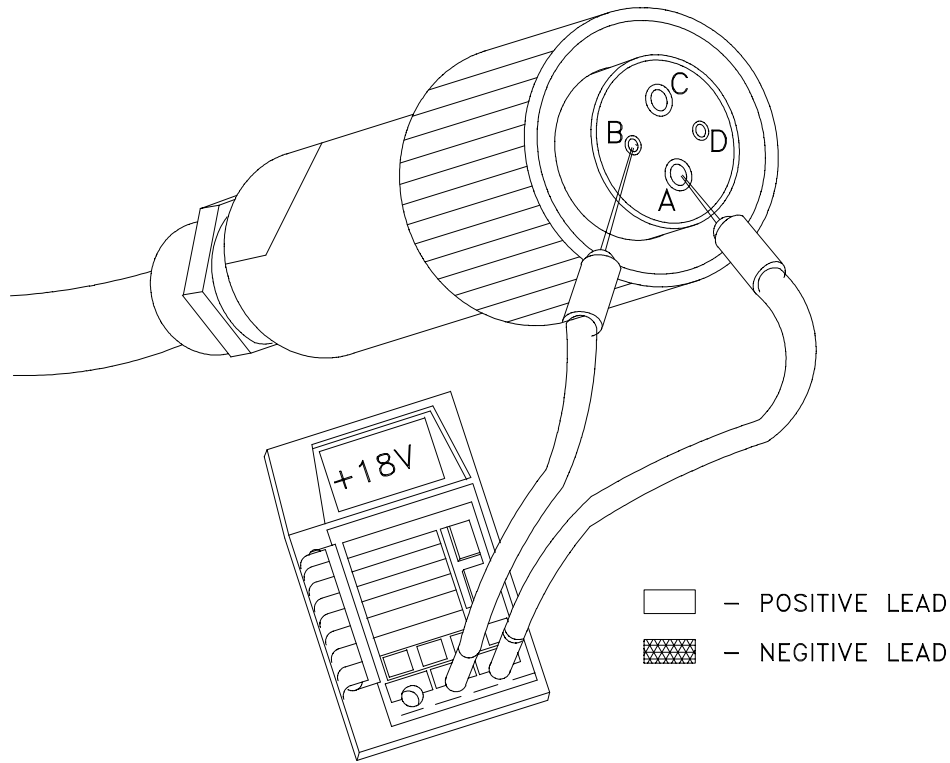

5.0 DIGITAL INPUTS

DRAWING # - LKB36-01

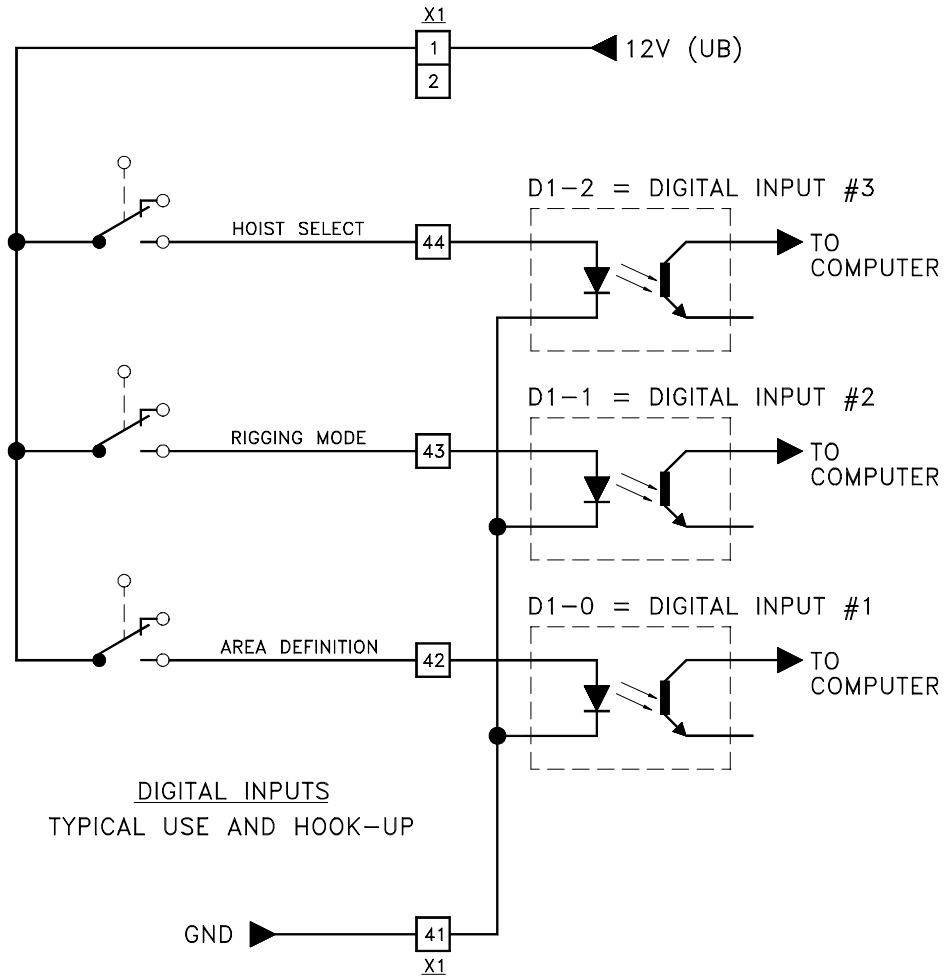

6.0 ANTI-TWO BLOCK CIRCUIT

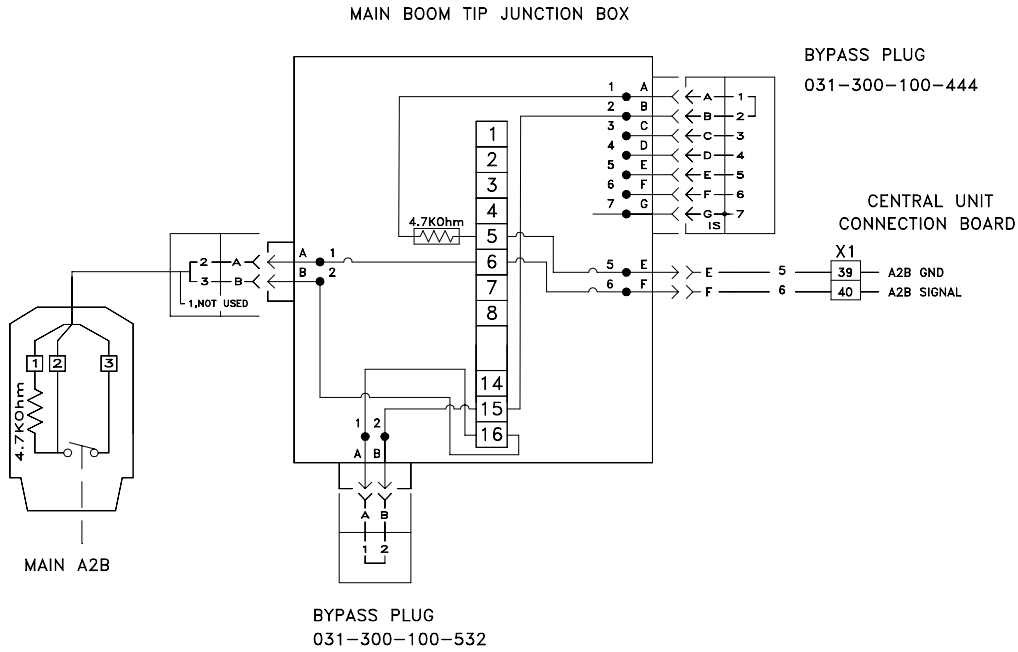

7.0 BOOM BASE CABLE REEL DIAGRAM

DRAWING # - 031-300-100-424

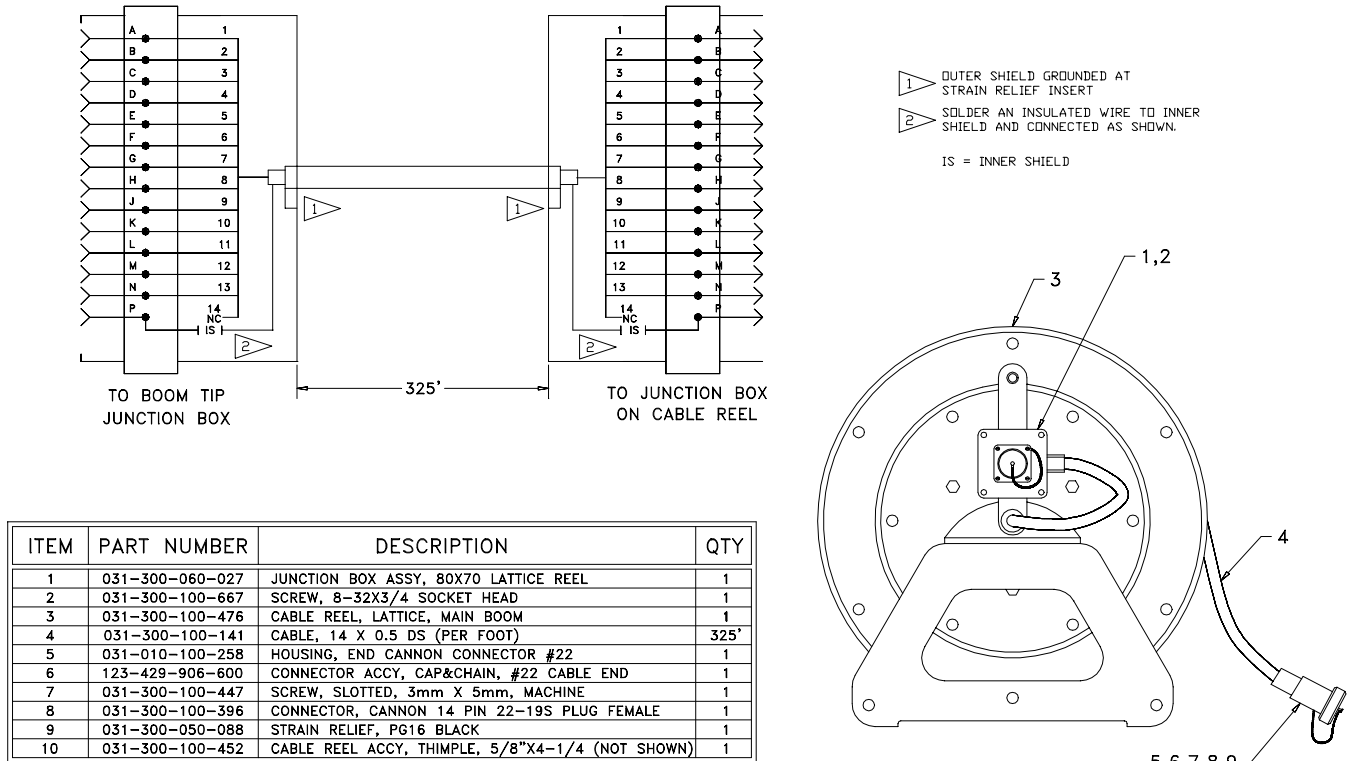

8.0 MAIN BOOM / JUNCTION BOX DIAGRAMS

MAIN BOOM NOSE
DRAWING # - 031-300-100-446

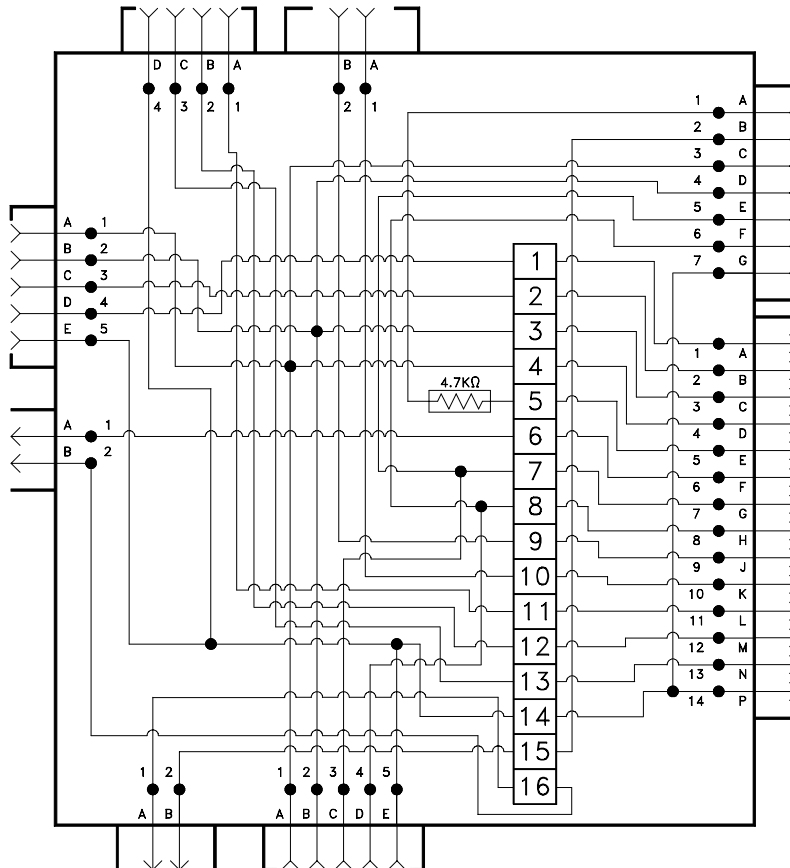

JIB NOSE
DRAWING # - 031-300-100-522

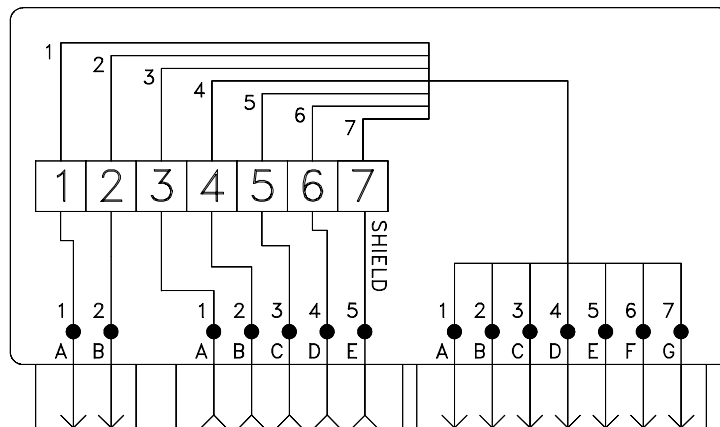

9.0 LUFFING ATTACHMENT / JUNCTION BOX DIAGRAMS

LUFFING LIMIT BASE
DRAWING # - 031-300-100-679

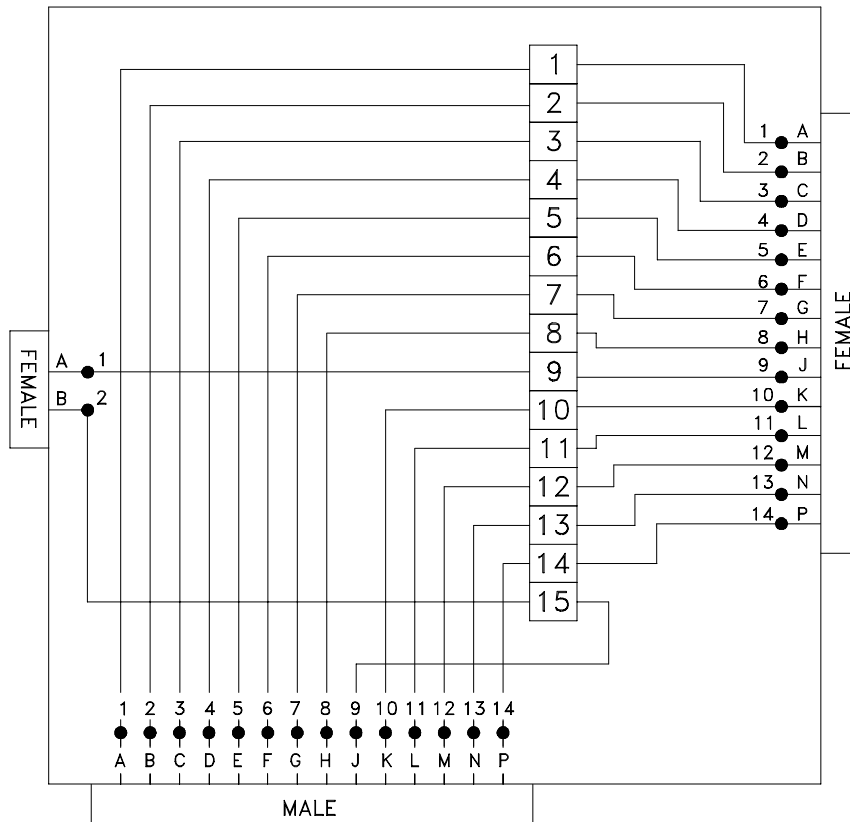

LUFFING JIB NOSE
DRAWING # - 031-300-100-535

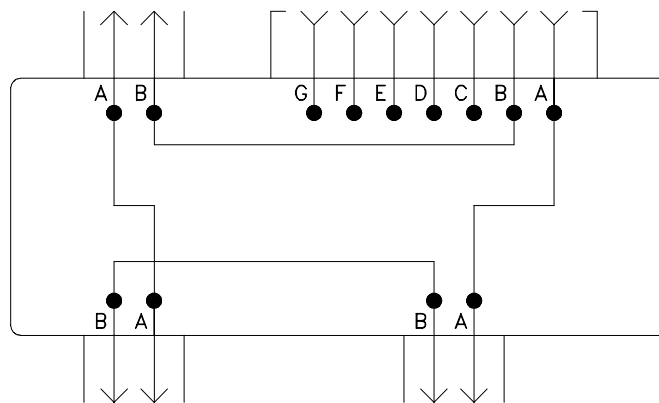

10.0 SYSTEM (24 VOLT) DIAGRAM

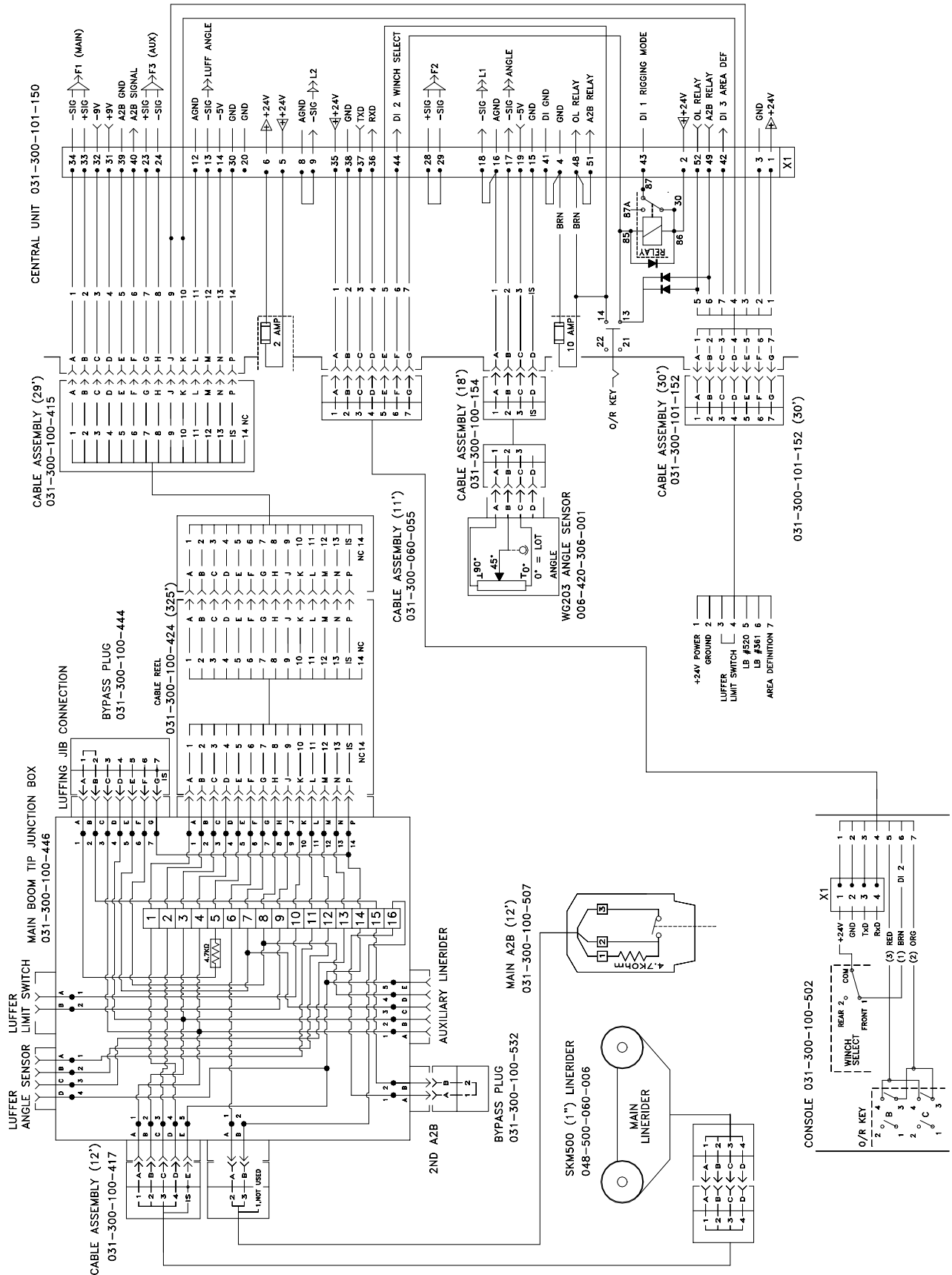

10.1 VERTICAL CONSOLE DIAGRAM

DRAWING # - 031-300-100-502

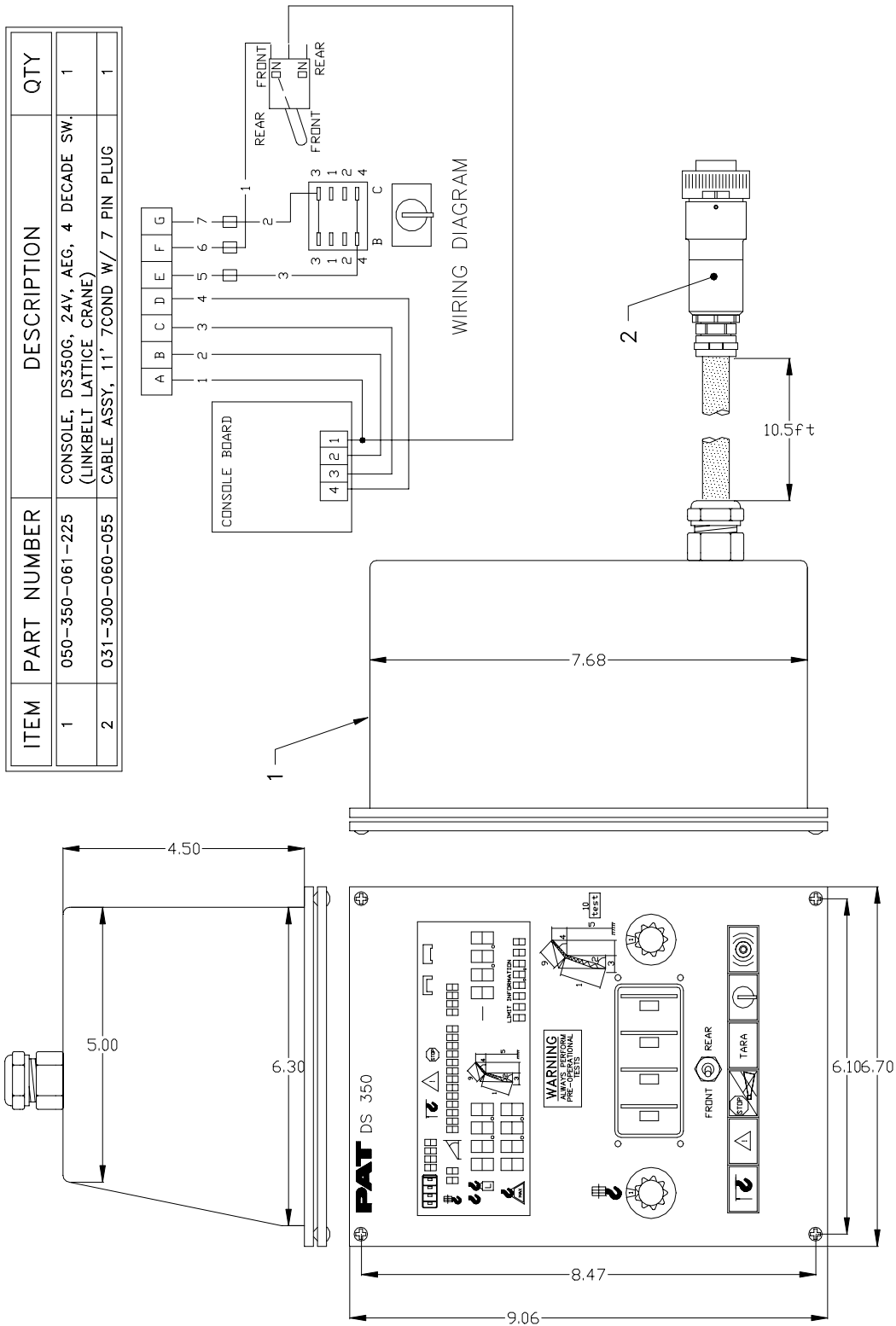

11.0 SYSTEM (12 VOLT) DIAGRAM

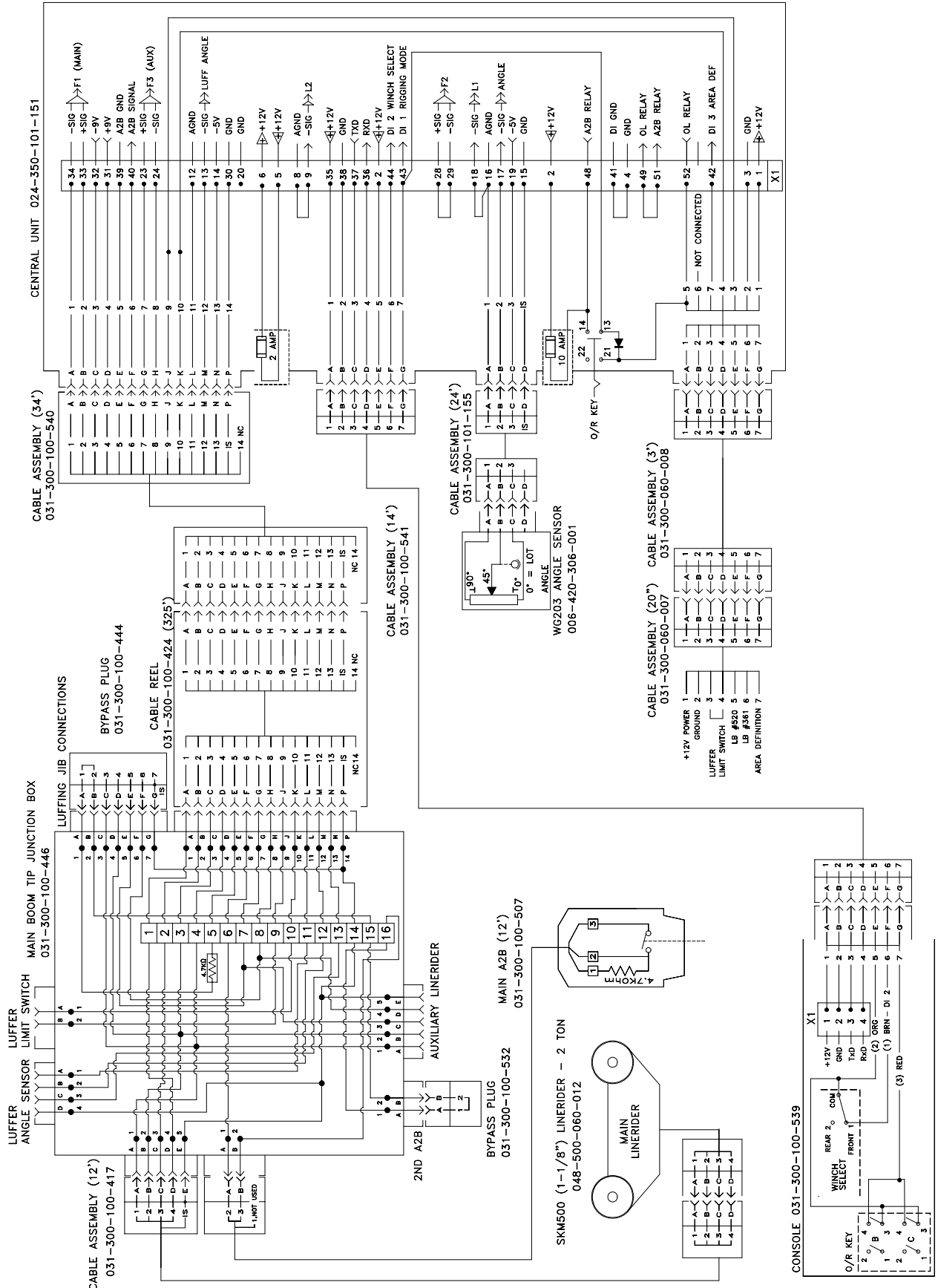

11.1 HORIZONTAL CONSOLE DIAGRAM

DRAWING # - 031-300-100-539

ITEM	PART NUMBER	DESCRIPTION	QTY
1	050-350-061-229	CONSOLE, DS350, 24V, AEG, 4 DECADE SW.	1
2	031-300-100-022	CONNECTOR, CANNON 7 PIN RECEPT #16	1
3	031-300-100-173	CONNECTOR ACCY, GASKET, SHELL # 16	1
4	031-300-100-174	SCREW, #4-40 X 1/2" PHILLIPS HEAD	4
5	031-300-100-175	WASHER, LOCK, #4	4
6	031-300-100-176	NUT, #4-40 HEX	4
7*	000-311-023-114	LAMP, 14V, LUMITAS	4
8*	000-311-023-128	LAMP, 28V, LUMITAS	-4
9*	050-350-110-116	STRAIN RELIEF ASSY, PG13.5 RED/WHT	-1
10	031-300-100-353	DECAL, WARNING FOR CONSOLE	1

* PARTS NOT SHOWN

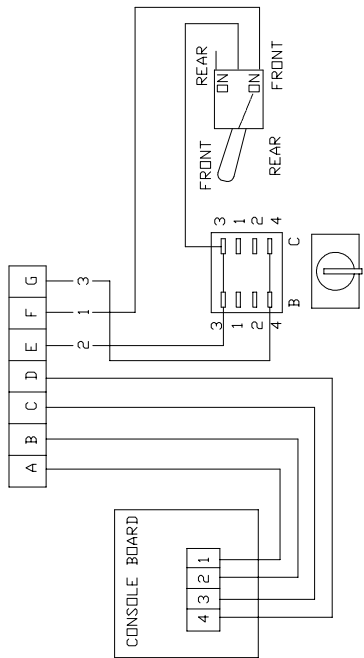

WIRING DIAGRAM

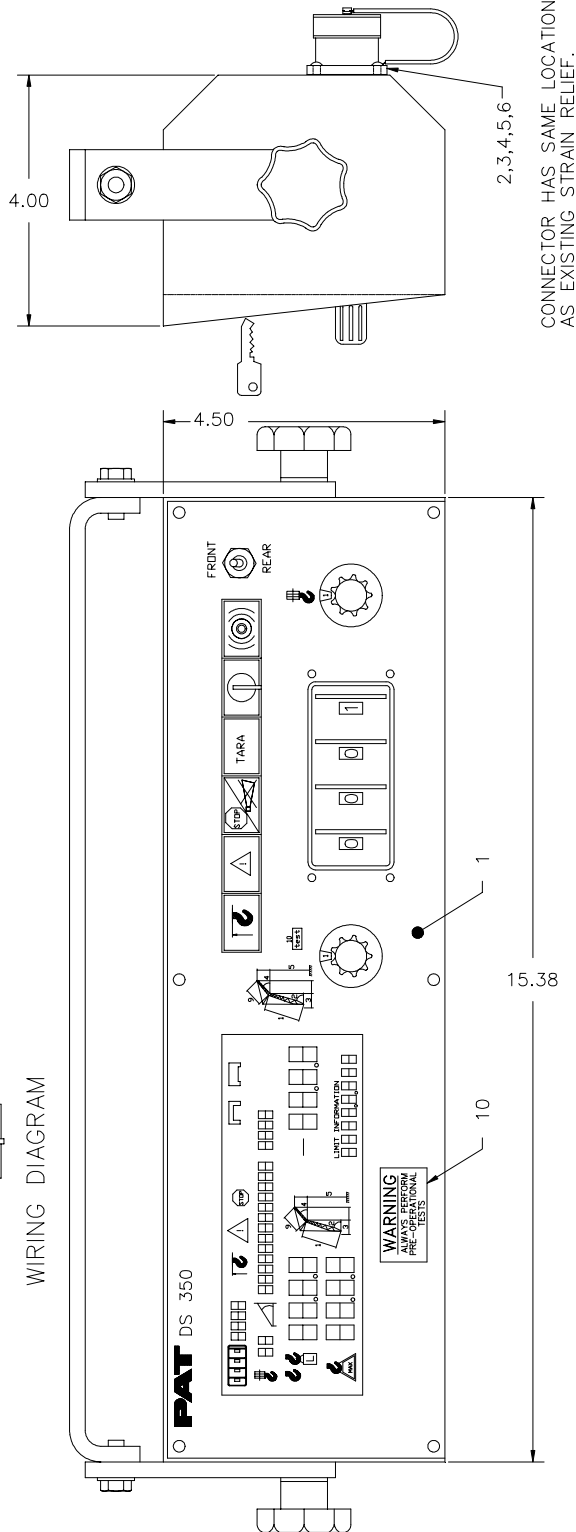

12.0 TERMINAL BOARD DESIGNATION

TERMINAL BOARD
DRAWING # - 024-350-060-739

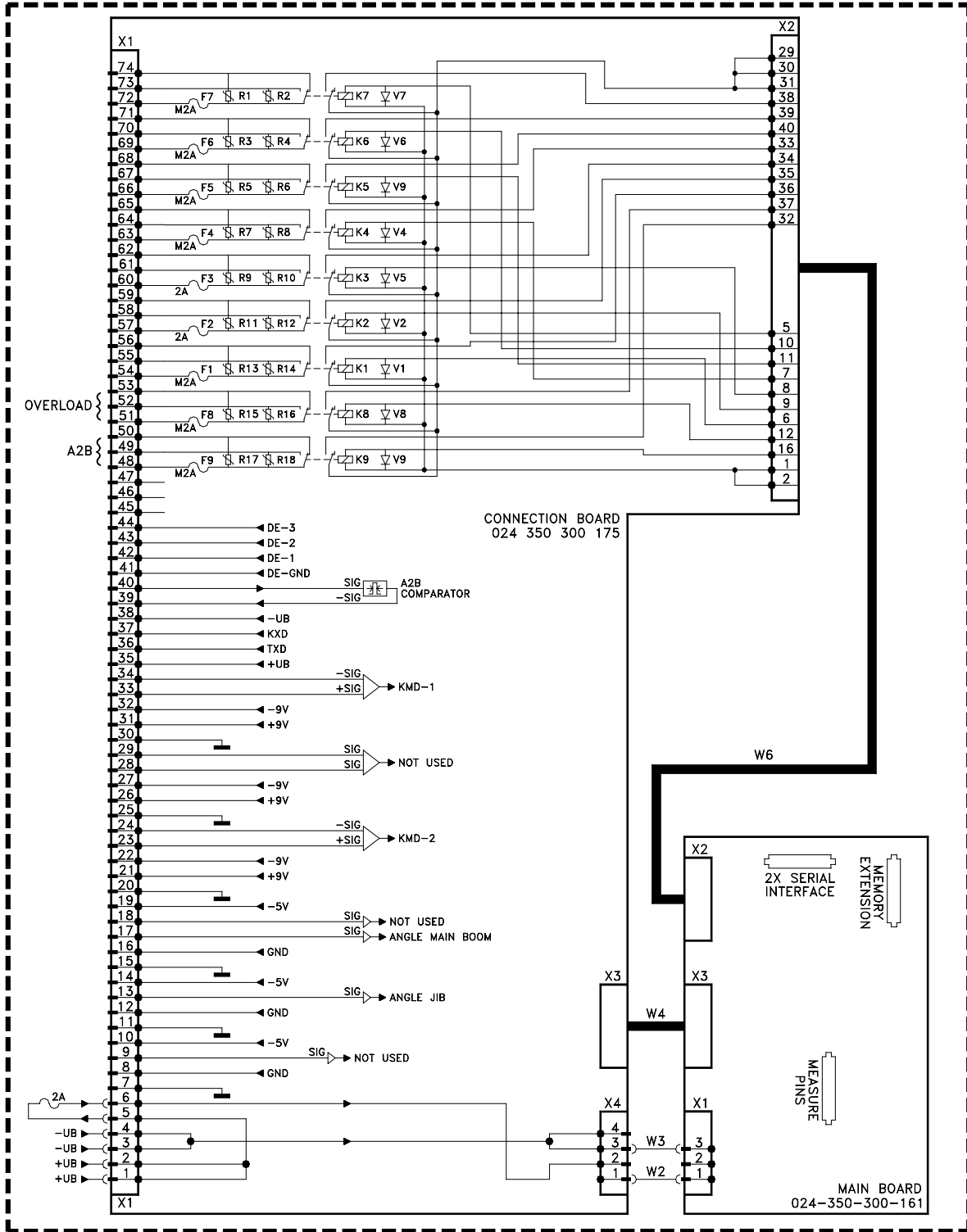

13.0 MAIN BOARD MEASURING POINTS

MEASURING POINT LAYOUT
DRAWING # - 024-350-300-081

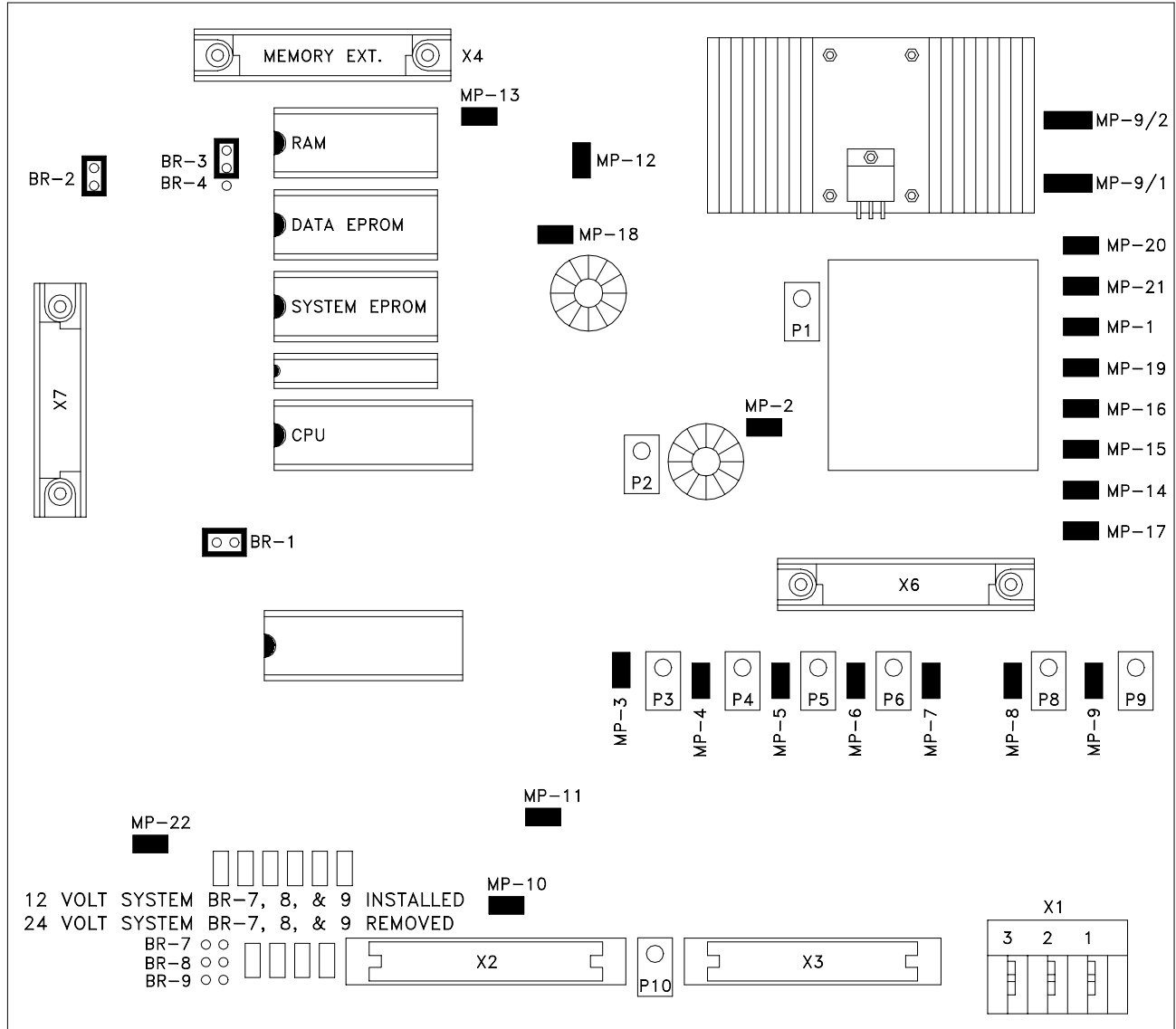

MP TEST POINTS

- | | |
|---|---------------------------|
| MP- 1 = +5V | MP-11 = GROUND |
| MP- 2 = -5V | MP-12 = +5V |
| MP- 3 = ANALOG MEASURING CHANNEL REFERENCE SOFTWARE | MP-13 = DIGITAL GROUND |
| MP- 4 = ANALOG MEASURING CHANNEL REFERENCE SOFTWARE | MP-14 = +9V |
| MP- 5 = ANALOG MEASURING CHANNEL REFERENCE SOFTWARE | MP-15 = ANALOG GROUND |
| MP- 6 = ANALOG MEASURING CHANNEL REFERENCE SOFTWARE | MP-16 = -9V |
| MP- 7 = ANALOG MEASURING CHANNEL REFERENCE SOFTWARE | MP-17 = +5V |
| MP- 8 = ANALOG MEASURING CHANNEL REFERENCE SOFTWARE | MP-18 = +5V |
| MP- 9 = ANALOG MEASURING CHANNEL REFERENCE SOFTWARE | MP-19 = -5V |
| MP-9/1 = COMPUTER GND | MP-20 = OPERATING VOLTAGE |
| MP-9/2 = CRANE GND | MP-21 = INPUT VOLTAGE |
| MP-10 = +3V REFERENCE VOLTAGE | |

