

Wireless Anemometer

Features

- Wind speed measurement range: 0 to 150 mph (0 to 241.4 km/h)
- Wind accuracy: +/- 3 mph (+/- 4.8 km/h)
- Radio range with line of sight: 4600 ft. (1400 m)
- Operates with one 'D' cell battery lithium 3.6V or alkaline 1.5V.
- Up to 4 years battery life for typical applications.
- Average of 20 month battery life for 24/24 hours use.
- Temperature range: -40°F to 140°F (-40°C to 60°C)
- Waterproof casing.
- Easy battery replacement, sealed with standard O-Ring
- Compatible with standard LSI systems.
- Two way communication with automatic radio power adjustment.

Applications

The GS025 anemometer can be used in a diverse range of applications to monitor wind speed and wind gust. Design to be used on moving crane it can also be used in a static condition.

General Description

The GS025 is a magnetically encoded anemometer. The wind speed values are computed from pulses of magnets inserted in the rotor. This means that this anemometer has no adjustment and thus never needs to be calibrated.



Figure 1, Wireless Anemometer p/n GS025

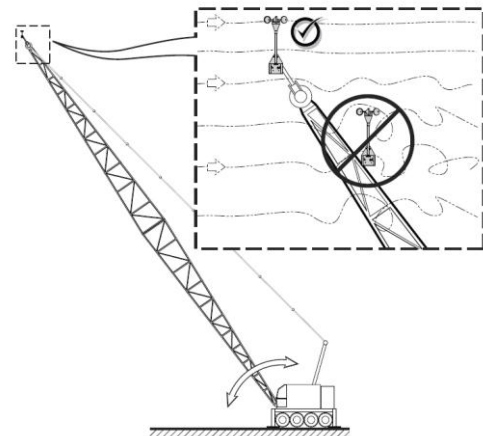

Figure 2, Anemometer installation on crane boom

Table of Contents

Features	1
Applications	1
General Description	1
Table of Contents	2
Ordering Information	2
Specifications	3
Absolute Maximum Ratings	3
Certifications	3
Dimensions and Installation	4
Materials:	4

Ordering Information

Model	Description
GS025-01	GS025, Radio Anemometer – FCC (902-928 MHz)
GS025-02	GS025, Radio Anemometer – CE (868-870 MHz)
PD058-A	Wind Cups Set Replacement
PA122	Wind Speed Sensor Pivoting support Replacement

GS025

Specifications

Parameter	Test Condition	Min	Typ	Max	Unit
Wind					
Resolution			1		mph
Accuracy			+/- 3		mph
Radio Power					
	GS025-01	0.001	0.001	0.020	W
		0	0	13	dBm
	GS025-02	0.001	0.001	0.020	W
		0	0	13	dBm
Radio Frequency					
	GS025-01	902	916	928	MHz
	GS025-02	868	868	870	MHz
Communication Range					
	Clear line of sight		1400		m
			4600		feet
Battery life					
40 hour/week	'D' cell lithium		48	54	Month
	'D' cell alkaline		12	16	Month
24/24 hours	'D' cell lithium		20	22	Month
	'D' cell alkaline		6	6	Month
Other					
Weight	GS025		0.7		lb
			(310)		(g)

Absolute Maximum Ratings

Parameter	Test Condition	Min	Typ	Max	Unit
Temperature range	Operating	-40		60	°C
		-40		+140	°F

Certifications

Safety
IEC 61010-1

Radio
FCC : parts 15.247, 15.205, 15.207

Industry Canada : RSS-210

CE : EN 300 220-3, EN 301 489-3

Dimensions and Installation

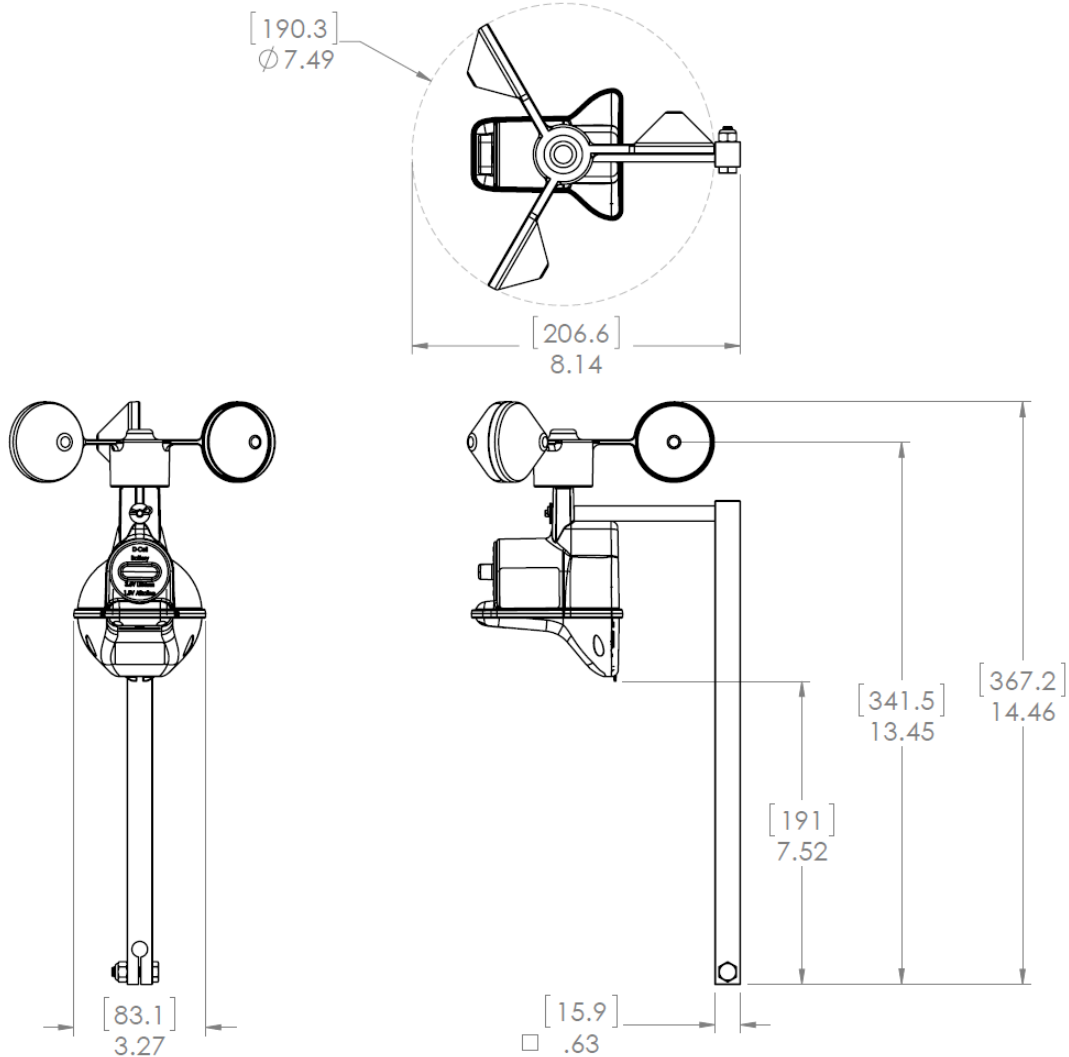

Figure 3: general dimensions (not to scale), in inches [mm]

For optimal performance, the anemometer should be installed in a place where the wind can flow freely with no obstruction or perturbation. See *Figure 2*. The utilization of the GS025 Anemometer is not limited to crane industry. It can also be used on any static structures.

The mounting bracket is designed to be welded on the structure or be mounted on a 3/8" (9.64mm) diameter shaft. The mounting bracket can thus be installed on a previous generation wind sensor support.

Materials:

The Anemometer (sensor box and wind cup) is entirely made of UV stabilized nylon. The mounting bracket is made of zinc plated steel.